

Reactive Metals for Large-scale, Seasonal Energy Storage

Stefano Passerini

Karlsruhe Institute of Technology, Helmholtz Institute Ulm, Helmholtzstr. 11, 89081
Ulm, Germany
Email: stefano.passerini@kit.edu

Present affiliation: Austrian Institute of Technology (AIT), Center for Transportation
Technologies, Giefinggasse 2, 1220 Vienna, Austria

On 28 November 2018, the European Commission presented its strategic long-term vision for a climate-neutral economy by 2050

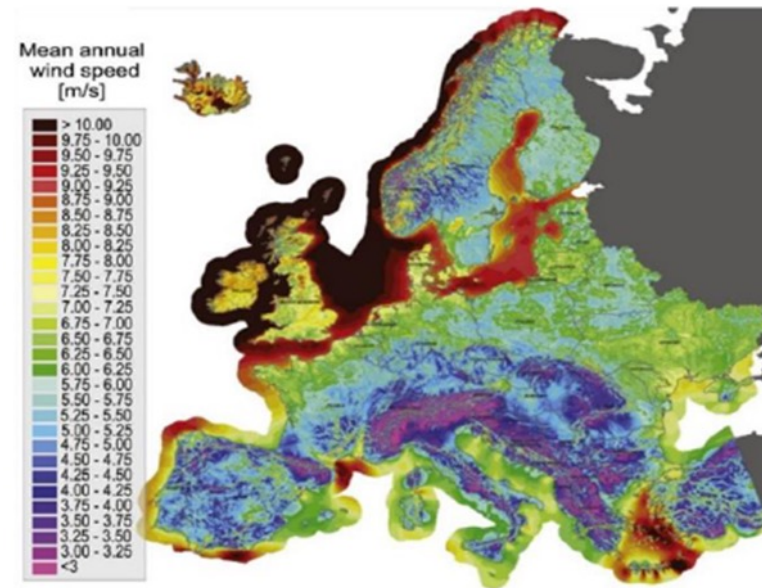
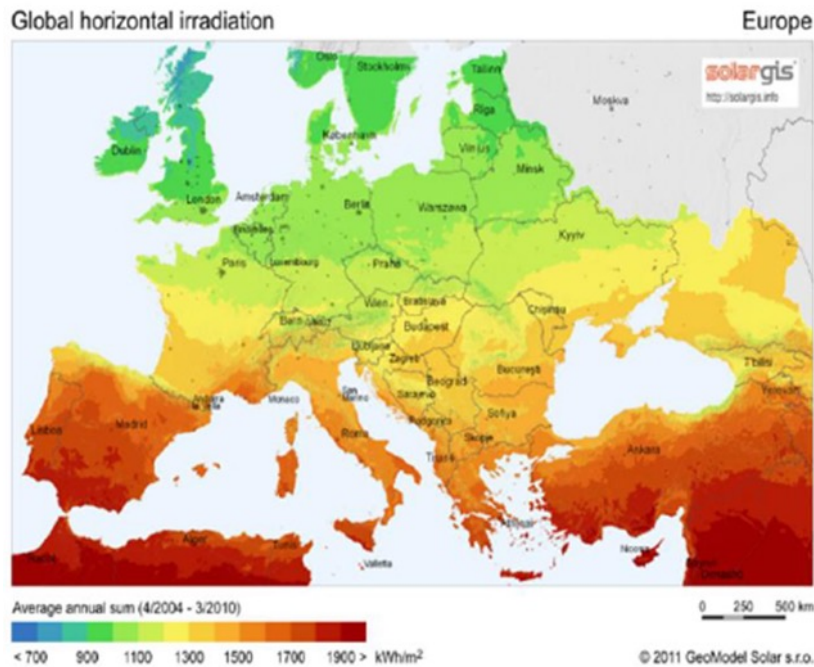

Source: Solargrids, Ad v. Wijk (TU DELFT)

Renewable Energy in Europe is far more than sufficient for the EU needs, but Energy storage is needed

Long-term RES fluctuation (Elaboration over 2015-20 generation data (ENTSO-E))

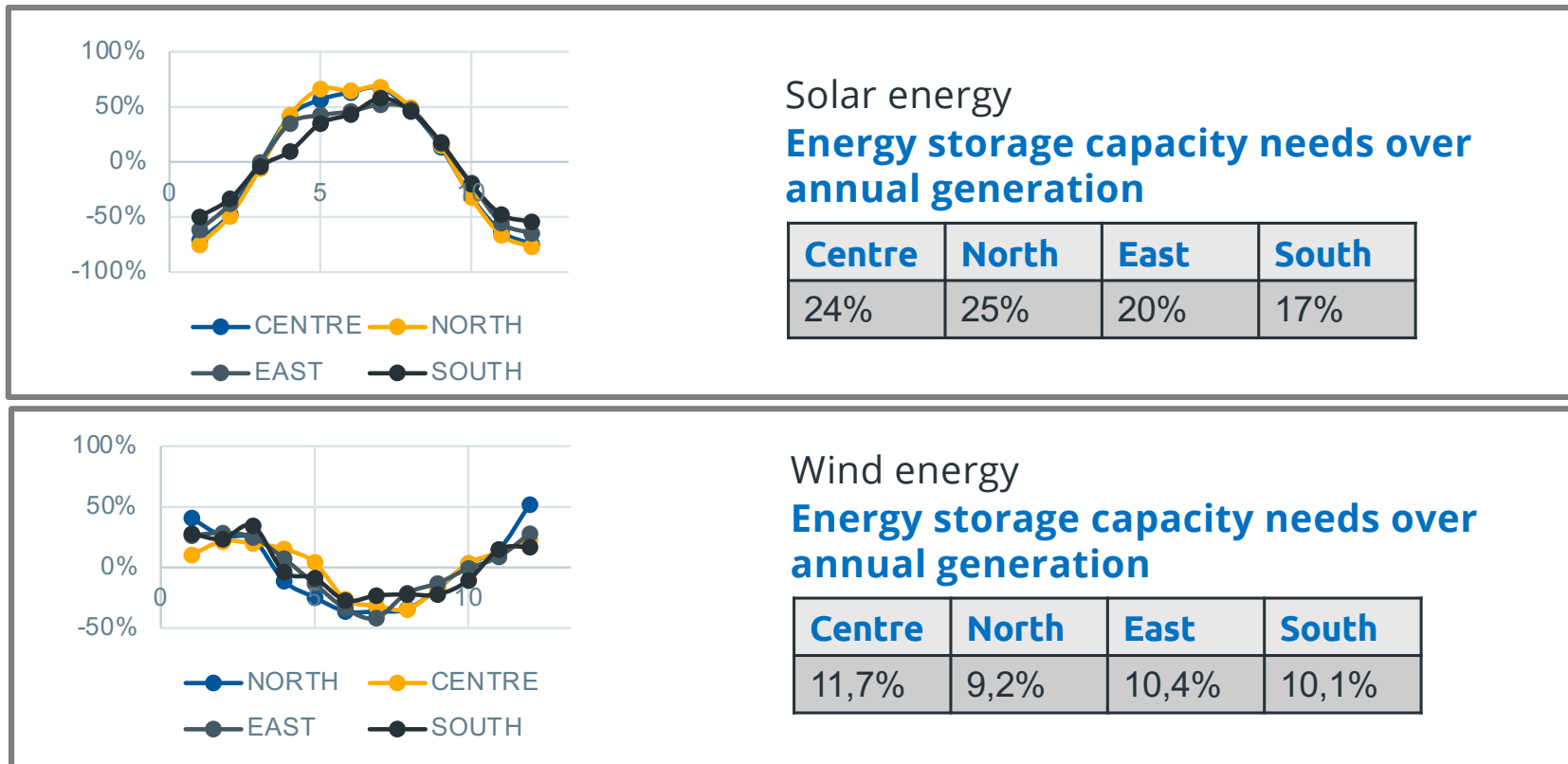

Energy storage is needed to match solar and wind generation variation in all European areas

Assumptions:

21399.2 TWh European primary energy consumption (2018)

36% Energy Storage cycle efficiency

5.8% POWER GRID LOSSES

Renewable Energy	Share	North Europe	Central Europe	South Europe
PV	45%	0.3	0.15	0.55
WIND	45%	0.65	0.05	0.30
Bio-mass & others	10%			

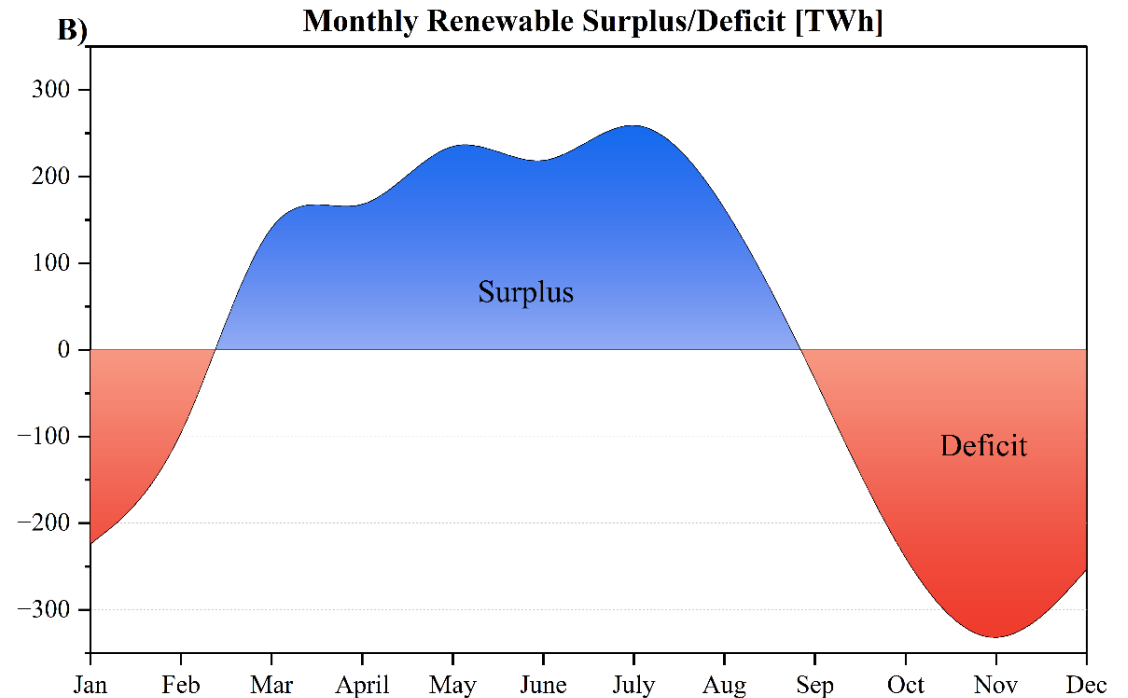

Energy storage capacity for EU energy independence

Seasonal: 1270 TWh

Weekly: 112 TWh

Daily: 19 TWh

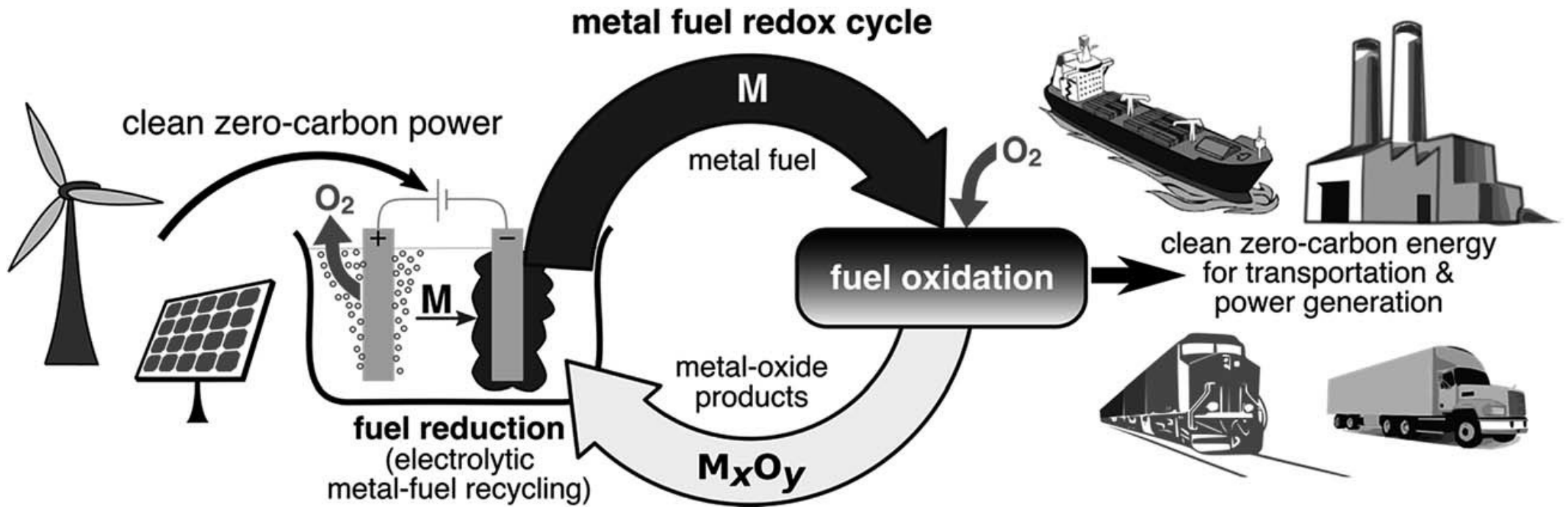

Abundant reactive metals (Al, Fe, Mg, Ca, Si, Na, ...) can store large amounts of energy

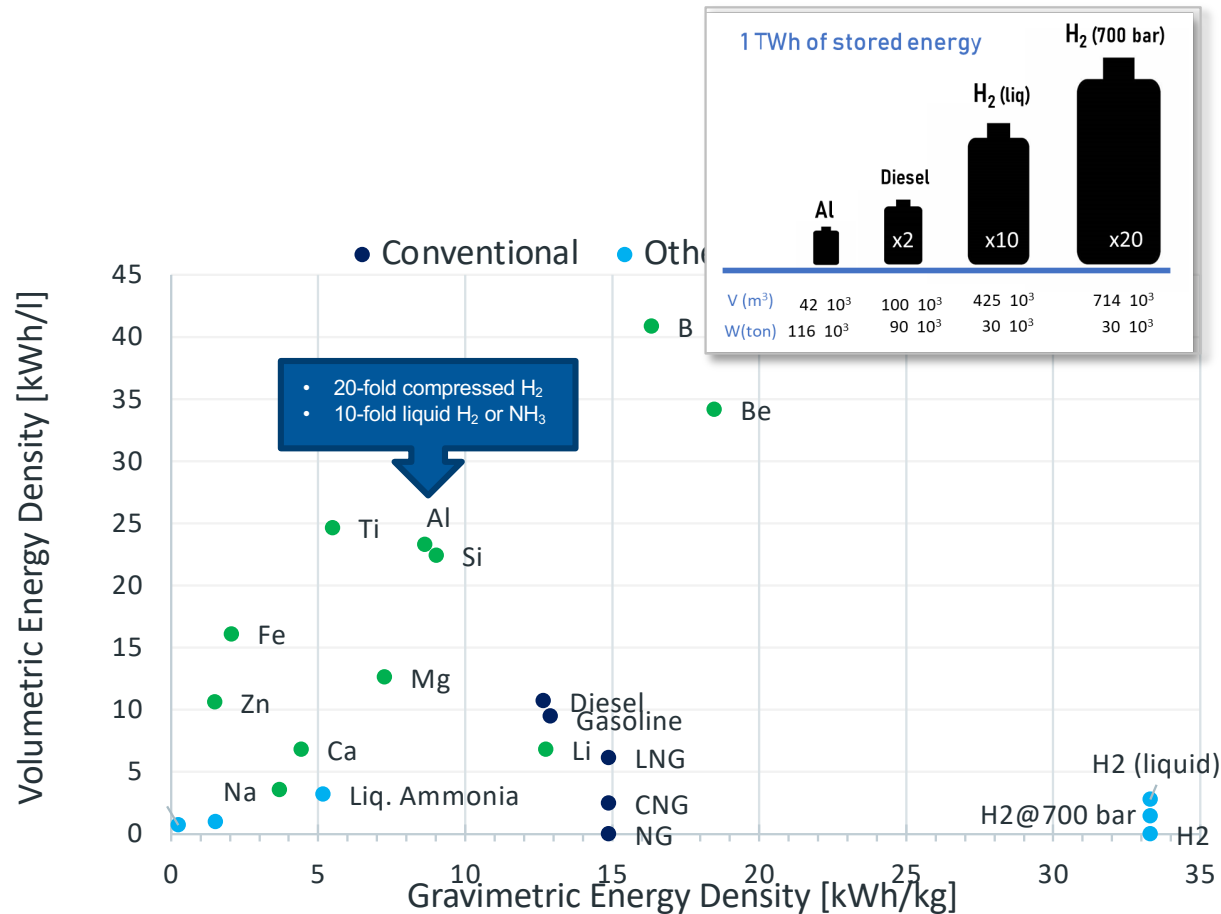

Requirements:

- Abundance
- High volumetric density
- High energy content
- High stability for storage
- No critical raw materials
- No toxicity or hazard risk
- CO₂ emission free
- No PFAs
- Local availability & Transportability
- Recyclability

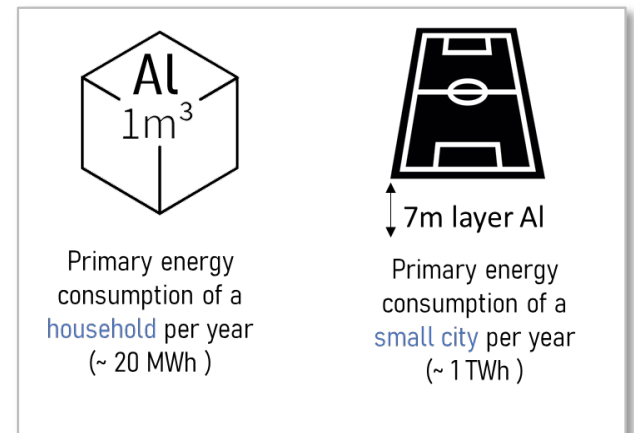

Aluminium appears very promising for easy, low cost, short- and long-term storage

Aluminum as energy carrier and storage medium

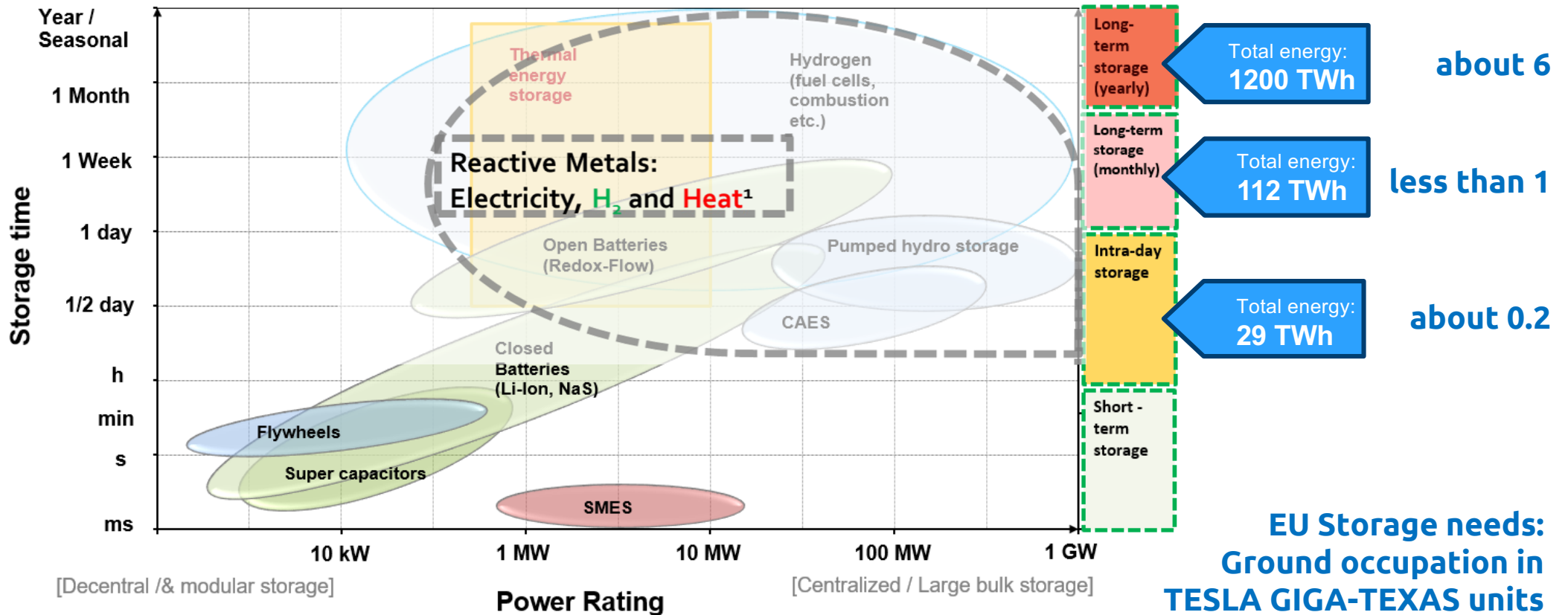

Barelli, L.; et al.. Reactive Metals as Energy Storage and Carrier Media: Use of Aluminum for Power Generation in Fuel Cell-Based Power Energy technology, 8 (9), Art. Nr.: 2000233. doi:10.1002/ente.202000233
 Taylor, Peter; et al. (2012). Pathways for Energy Storage in the UK. Centre for Low Carbon Futures, York.
 Baumann, M.; et al. A review of multi-criteria decision making approaches for evaluating energy storage systems for grid applications. 2019. Renewable & sustainable energy reviews, 107, 516-534. doi:10.1016/j.rser.2019.02.016

Hall-Heroult Process

- Zero CO₂ emission, only O₂
- No **perfluorochemicals** (PFCs) emitted
- 20 % less energy and flexible power
- 50 % less space, see figures
- 40 % less investments
- 15-30 % less operational costs

↑
CO₂ & PFAs



Conventional Al-smelting

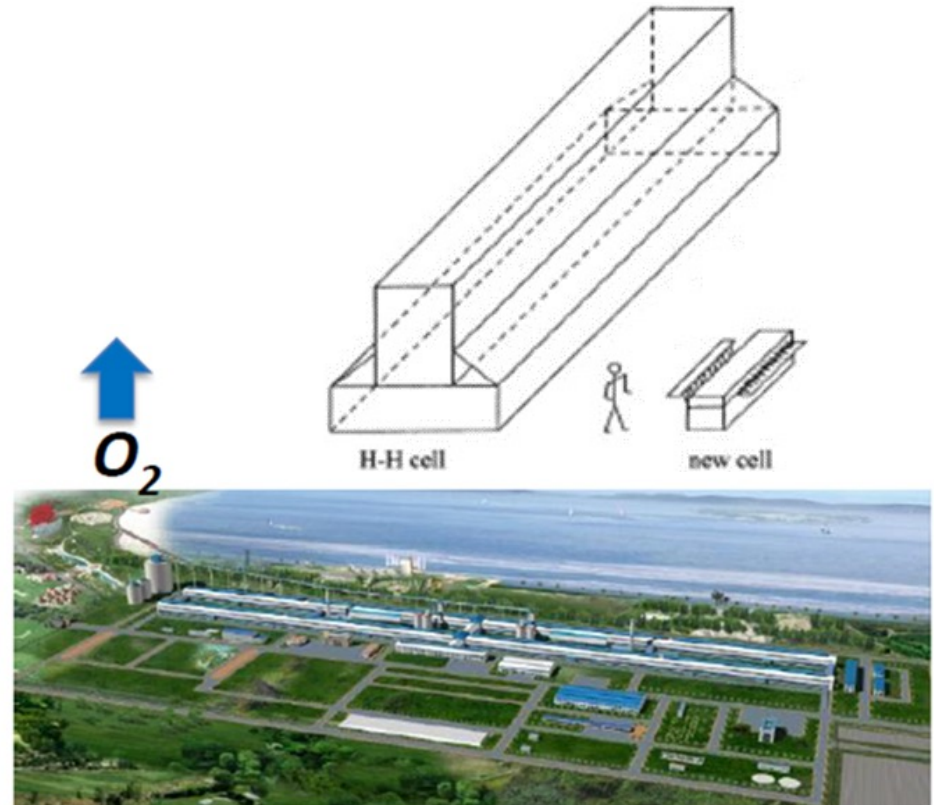

Inert anode Al-smelting

THERMODYNAMIC CONVERSION

(wet combustion)

CHEMICAL OXIDATION OF ALUMINUM



(per 1 kg of Al)

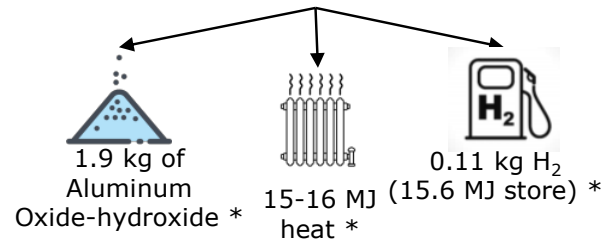

- Stored energy is converted into H₂ and heat
- H₂ and heat are transformed into electricity via fuel cells and gas turbines
- RTE of 36%

ELECTROCHEMICAL CONVERSION

(primary batteries)

ELECTROCHEMICAL OXIDATION OF ALUMINUM



(per 1 kg of Al)

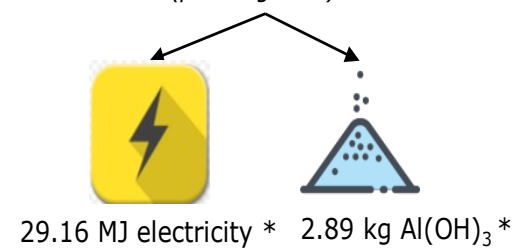

- No thermal energy losses
- Direct electricity
- RTE up to 50%

THERMODYNAMIC CONVERSION

(wet combustion)

CHEMICAL OXIDATION OF ALUMINUM



(per 1 kg of Al)

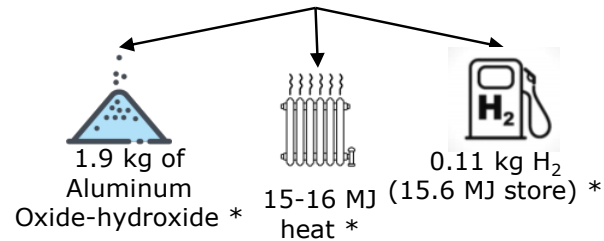

- Stored energy is converted into H₂ and heat
- H₂ and heat are transformed into electricity via fuel cells and gas turbines
- RTE of 36%

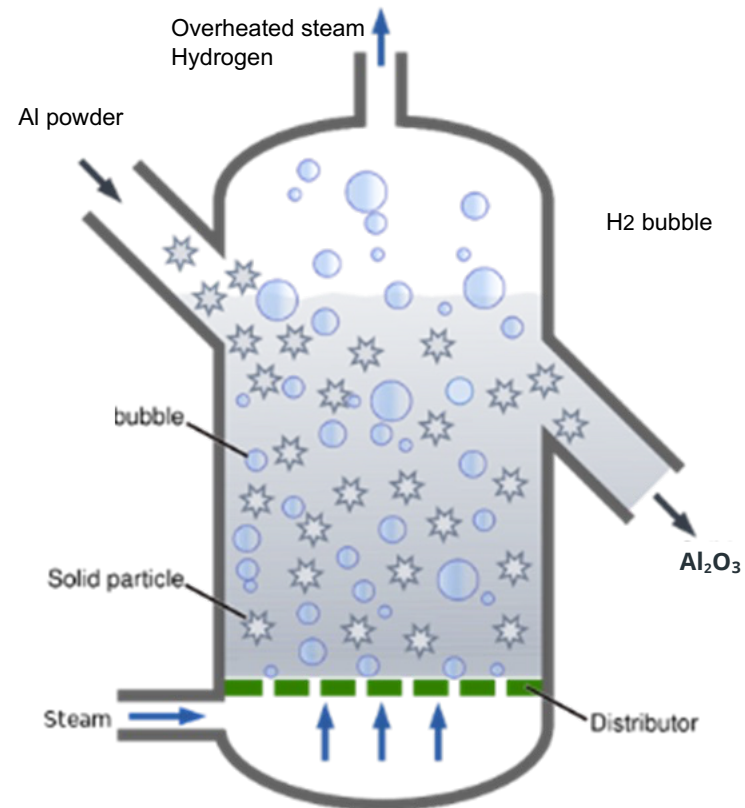

Fluidized Bed reactor – simple water combustion process

Implementation Scenario – Business case: BEV and FCEV charging stations

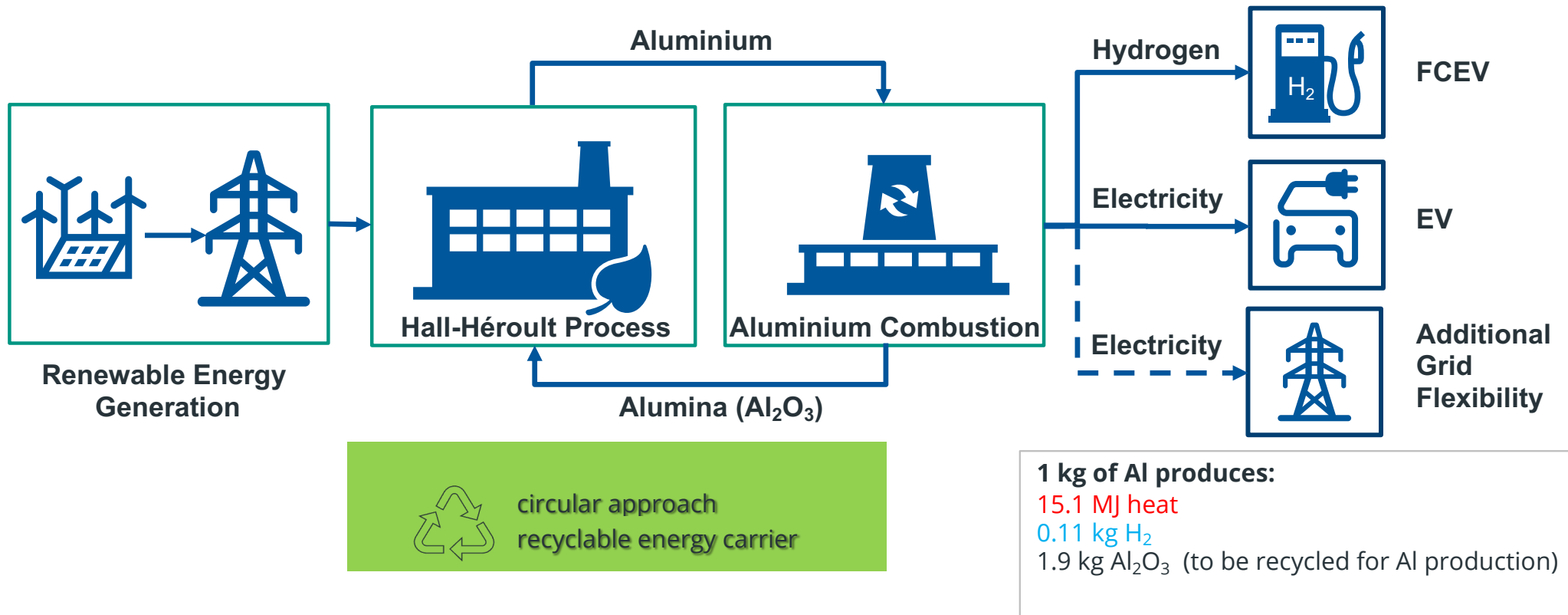
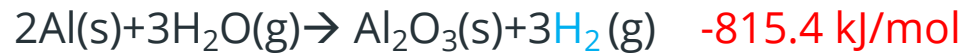

RTE, vol. energy density of various P-to-P technologies employing different energy carriers

Energy Carrier	Conversion Technology	Round Trip Efficiency (RTE)	Energy Density [kWh/L]
Al	Aluminium Wet – Combustion (ST,GT, & SOFC)	35.6 %	23.5
H ₂	PEM Electrolyzer – PEM Fuel Cell (PEMFC) Reversible – Solid Oxide Cell	30% (H ₂ @200 bar) 48% (H ₂ @70 bar)	0.53 0.2
Methanol / DME	Solid Oxide Electrolyzer (SOE) / H ₂ to methanol-DME / Solid Oxide Fuel Cell (SOFC)	36% (26.5%*)	5.5
Gasoline	SOE/ H ₂ to gasoline/SOFC	27% (20%*)	8.8
LNG	SOE/TSA dehydration, H ₂ and CO ₂ membrane separation/SOFC	28% (23%*)	5.8

RTE values include the thermal (1750 kWh/tCO₂) and electric (250 kWh/tCO₂) energy consumption for CO₂ trapping via low temperature absorption technology

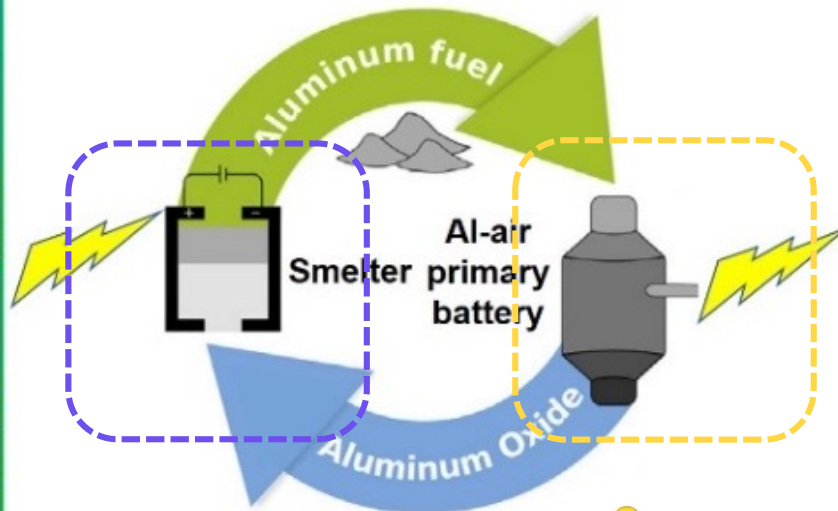
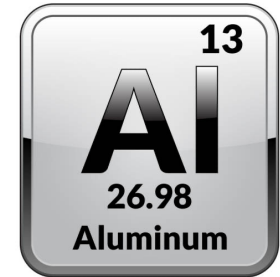

Metal to power

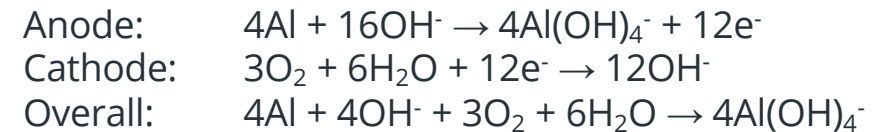
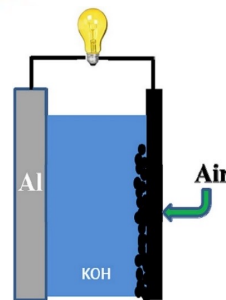

State-of-the-art: Voltage and energy fading

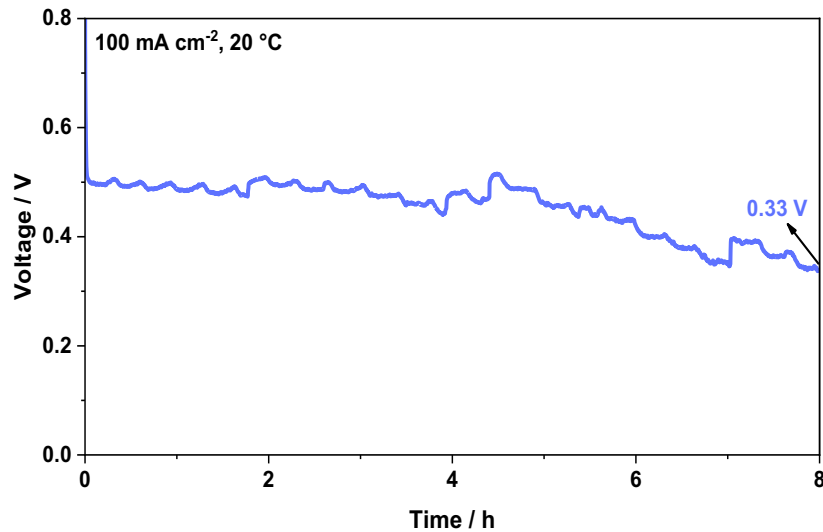

Previous literature: accumulation of Al(OH)₃ on the surface of Al anode



Development

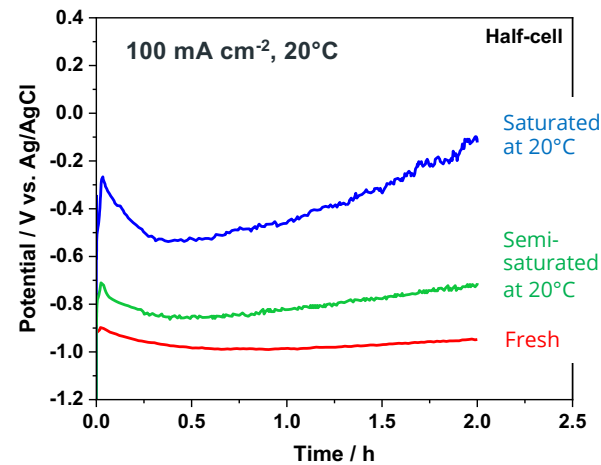

The voltage degradation is due to increasing Al(OH)₄⁻ in the electrolyte, corresponding to decreasing OH⁻

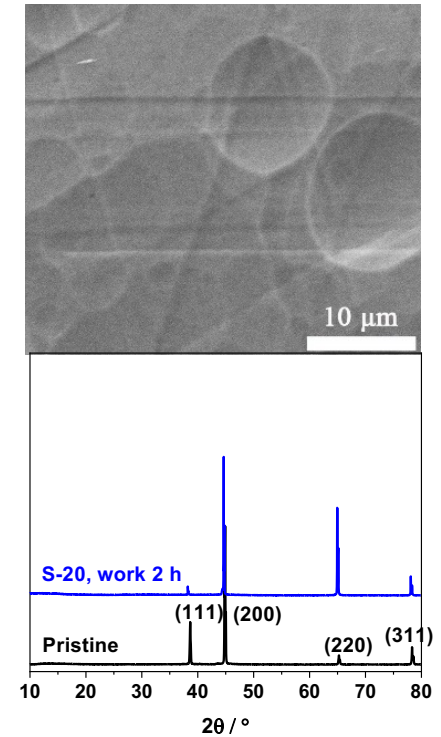

Need to adjust the electrolyte composition

Half cell: Al foil (3.4 cm²) as working electrode; Ni foam (60 cm²) as Counter electrode
Ag/AgCl electrode as reference electrode; 40 mL (excess) electrolytes

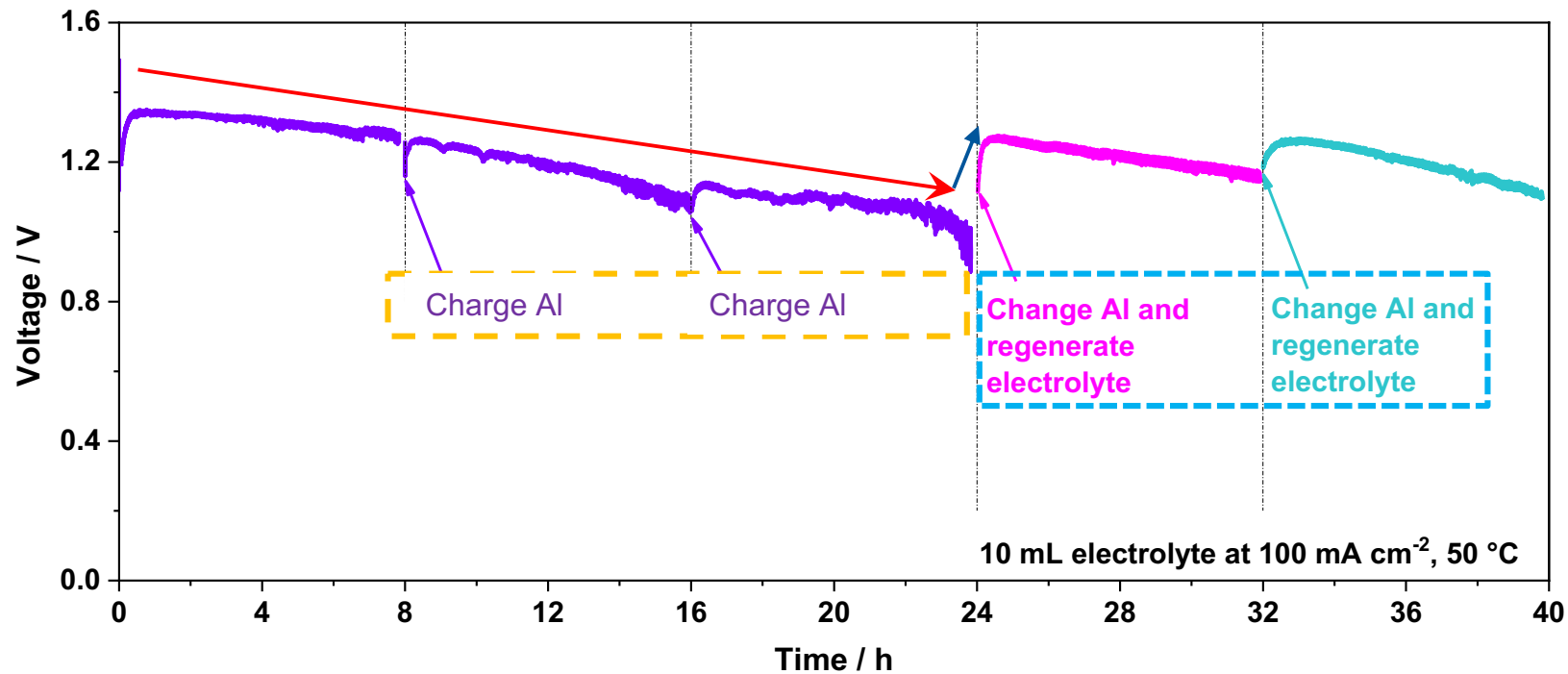

- 0-24 h: Long-term discharge leads to **decreased voltage and specific energy**
- @24 & 32 h: The **voltage and specific energy are effectively recovered** by electrolyte's regeneration

Full cell: Al anode (1 cm²) ; MnOx-based air cathode (4.5 cm²)

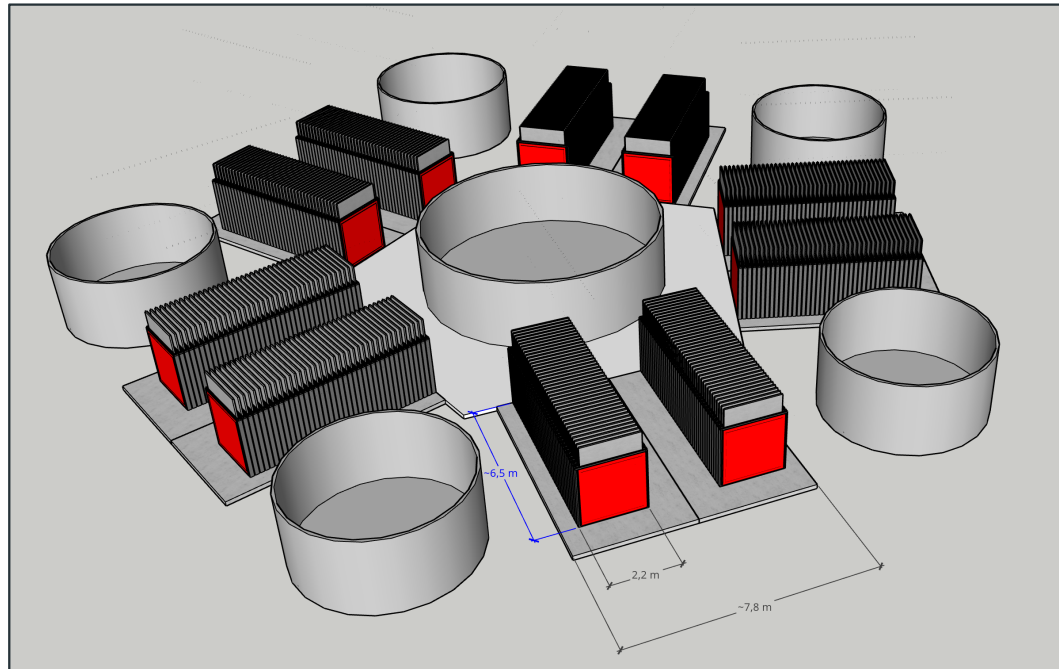

Aluminium-air battery system with 400 cells and 1 MW power capacity.

System design aspects

System Parameters	Quantity	Unit
Design power	1	MW _e
Discharge duration	8	hours
Aluminium flow rate	0.2331	kg/kWh _e
Efficiency	~60	%
Heat rate	3.35	kWh/kg _{Al}
Number of Cells	400	cells
System lifetime	20	year
Annual operation days	360	days

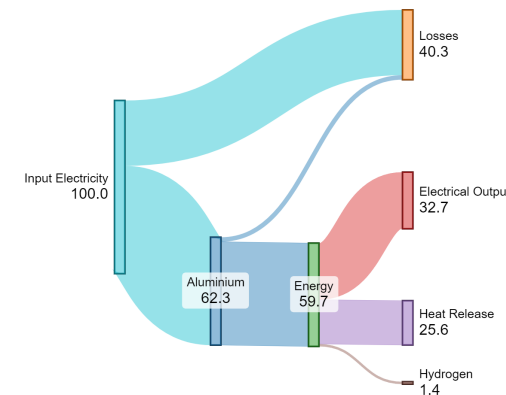

Round-trip efficiency: **~33%**

Might go up to: ~58 (with heat recovery)

Innovative Na batteries for long-term energy storage

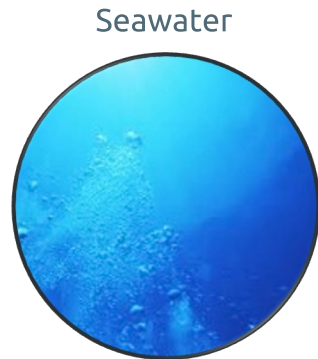

Seawater



Energy Production

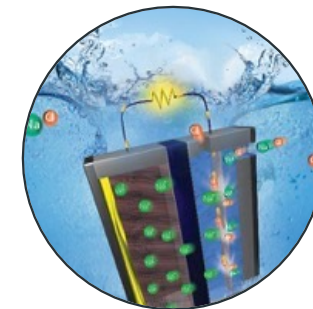

"Seawater battery"

Energy Storage and Delivery

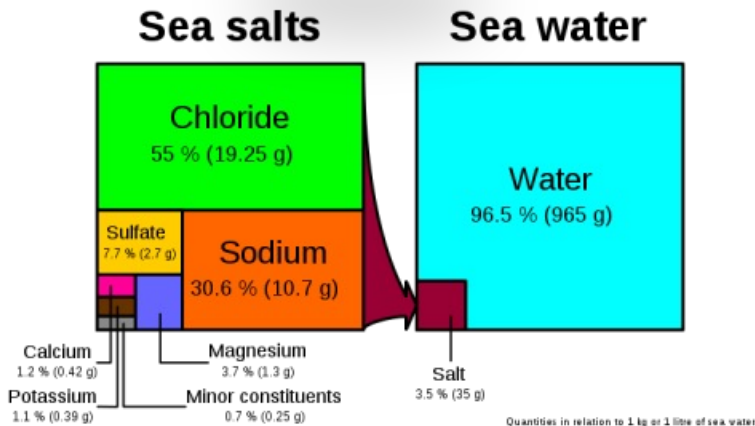

Mechanism:

Seawater batteries store energy as metallic Na through the electrolysis of NaCl

Sustainability:

Seawater is the most abundant and homogeneously distributed chemical on Earth

Long-term collaboration with
 Prof. Youngsik Kim UNIST
 Prof. Yongll Kim Gachon University

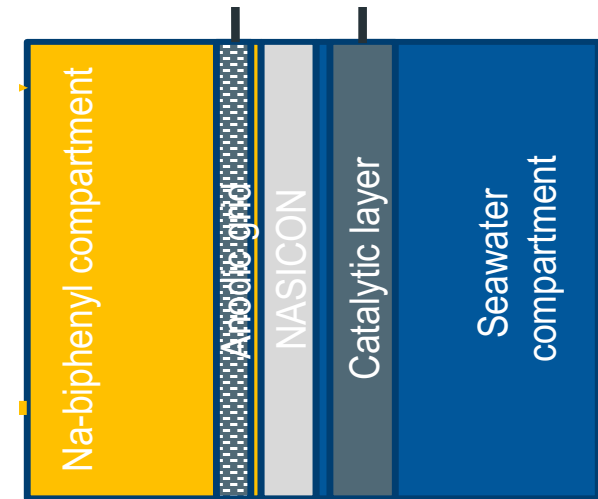
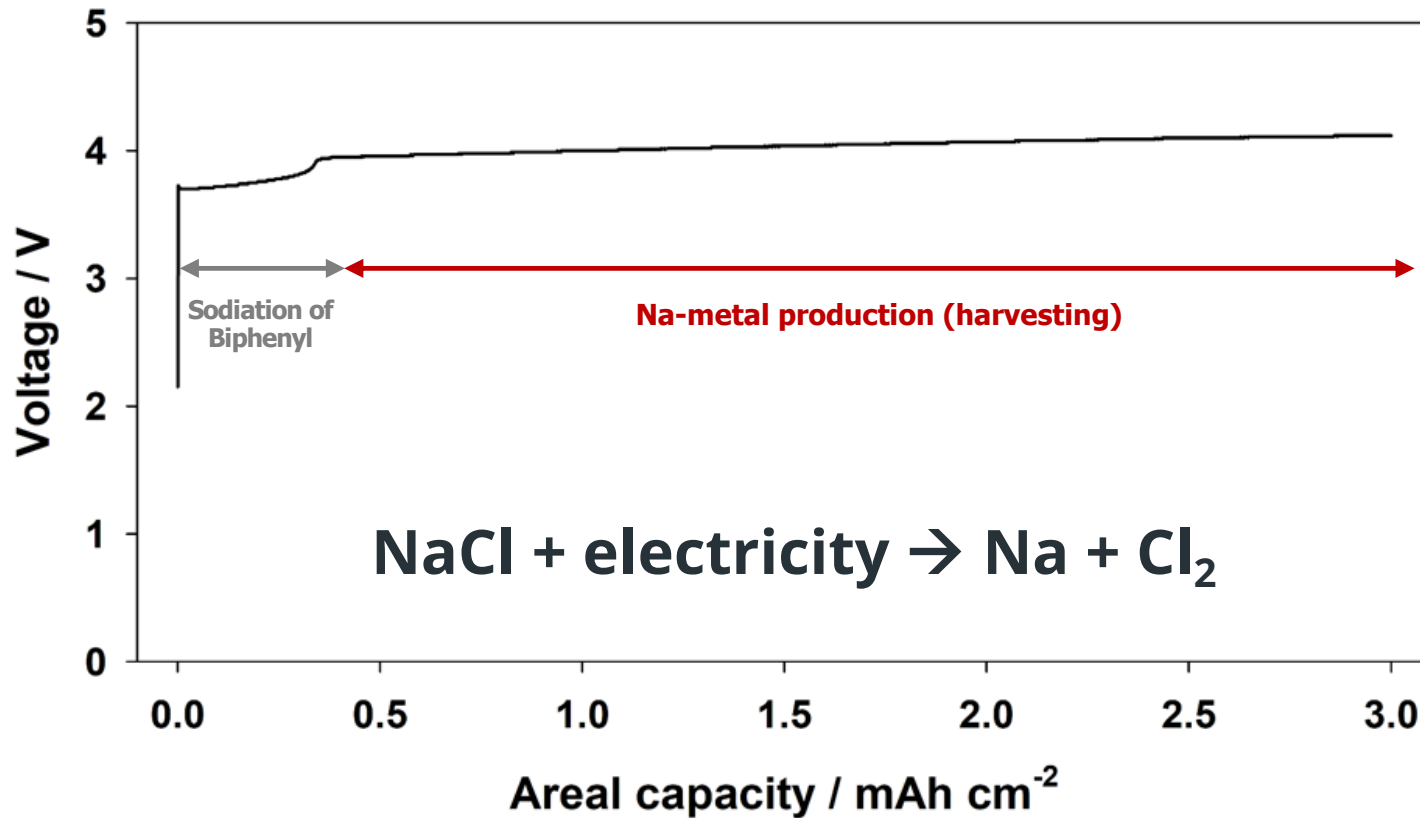

Sodium and Chlorine production and water desalinization

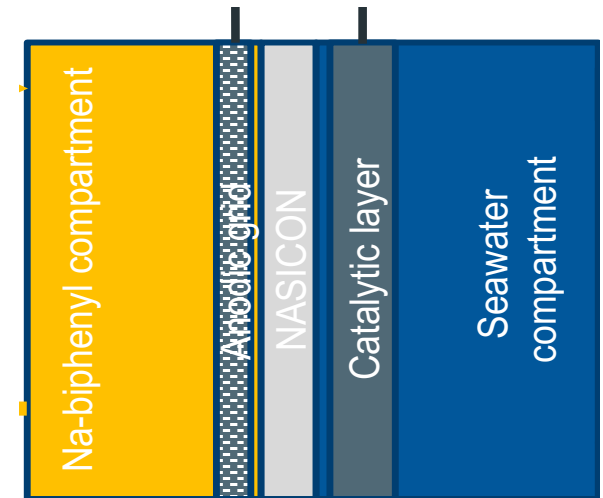
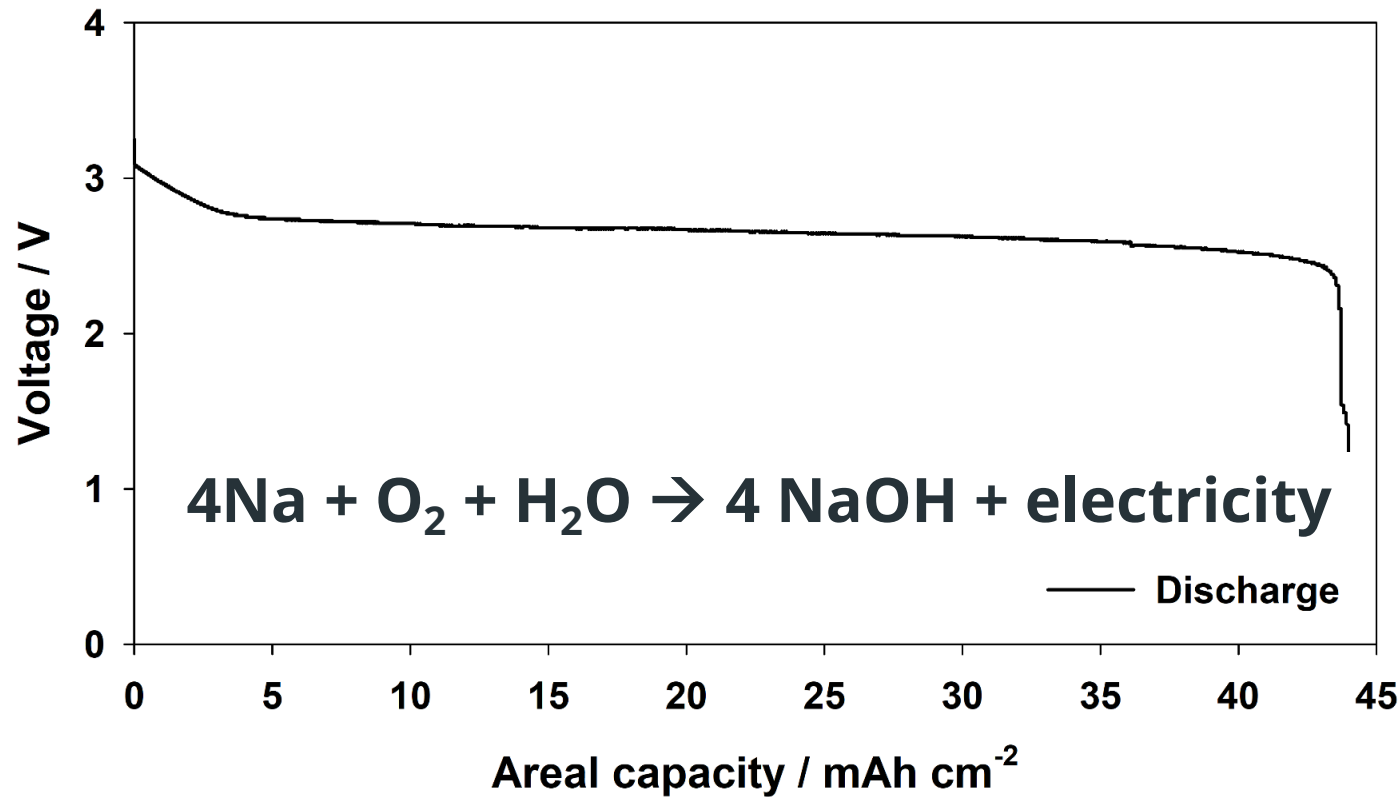

Power generation from Sodium and Seawater demonstrated
 Applicable for marine transportation, on-shore and off-shore power generation

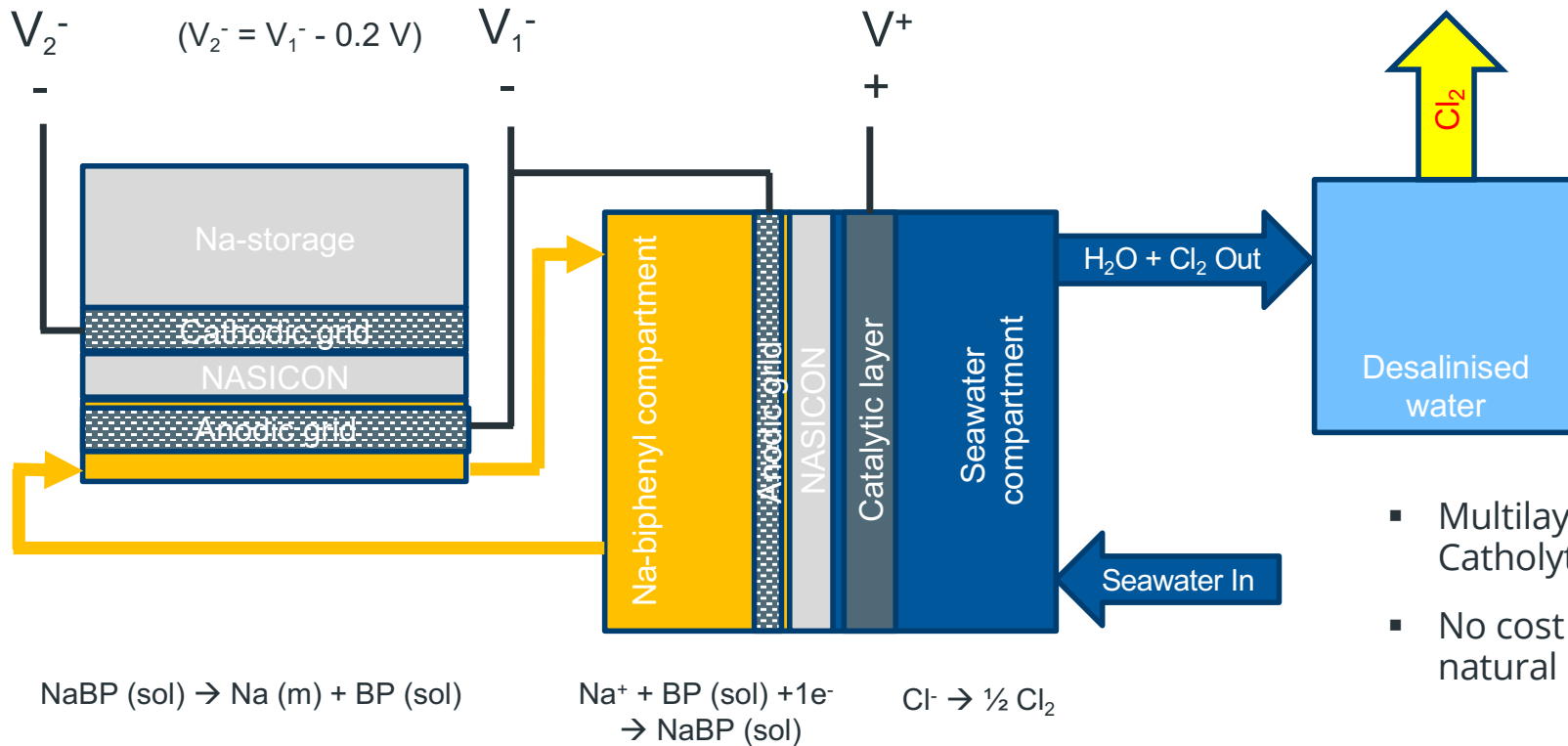

- Multilayer electrolyte system: Catholyte | Solid electrolyte | Anolyte
- No cost for cathode using unlimited natural seawater (0.47 M NaCl)

Na-storage Unit

Na-extraction Unit

Cl₂-extraction Unit

The energy stored is proportional to the amount of Na stored
 By-products: Chlorine, Desalinated water and CO₂ trapping

Implementation Scenario – Business case: Sardinia

Energy characteristics:

- No natural gas network
- Old energy infrastructure
- Great Renewables potential

Primary energy use: 23.5 TWh/yr

Seasonal storage needs: 4.43 TWh

PV (69 km²) + Seawater Battery

High volumetric energy density
High energy efficiency (>70%)

Chlorine production

Desalinated water production

CO₂ trapping

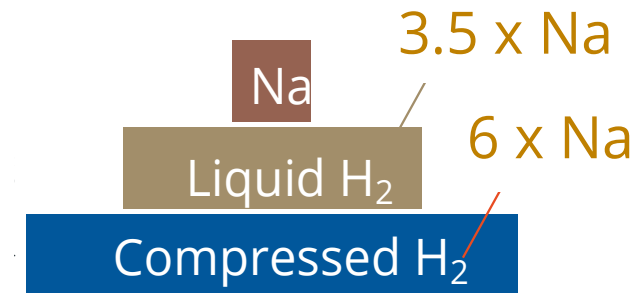

131 mln di m³
(1.64 mln inhabitants)

57,700 tons of CO₂
36.2 g CO₂ per kWh of stored energy

Al, Na and other abundant metal-based energy systems can help addressing several (and rather different) energy storage issues:

Sustainable Transportation (existing and fast-growing market)

Innovative approaches for marine transportation (Al conversion and Na-seawater batteries)

Delocalized power generation for the EV charging infrastructure via reactive metals (Al, Fe, Na, Ca, Mg, ...)

Energy Storage (huge market perspectives)

Stationary storage (Na-seawater batteries)

Seasonal/annual electrochemical and hybrid storage via reactive metals (Al, Fe, Na, Ca, Mg,)



Acknowledgment



Federal Ministry
of Education
and Research



www.hiu-batteries.de



MINISTERO DELLA
TRANSIZIONE ECOLOGICA



be
displa
yed.

University of Perugia Prof. Linda Barelli

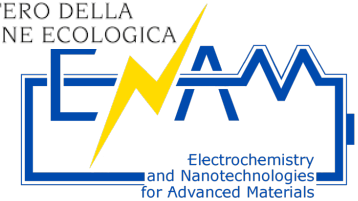



Towards realistic solid-state batteries: overcoming transport limitations in electrodes



Why is the world (seemingly) going solid?

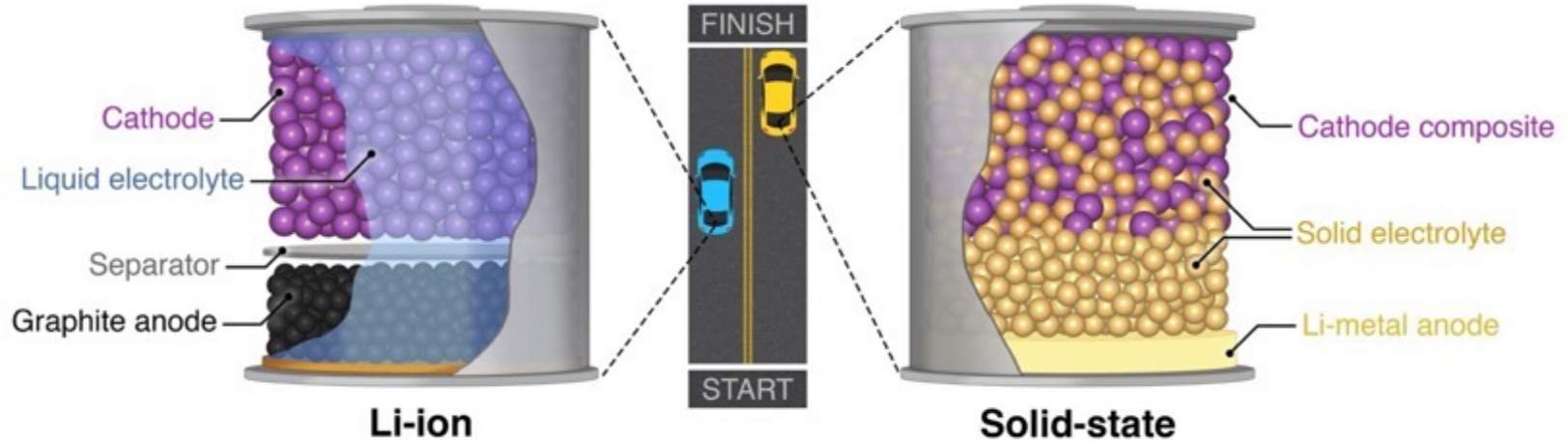

Projected higher safety = no liquid

Projected higher energy density = longer driving range

Projected higher power density = faster charging

Diverse options come with a variety of challenges

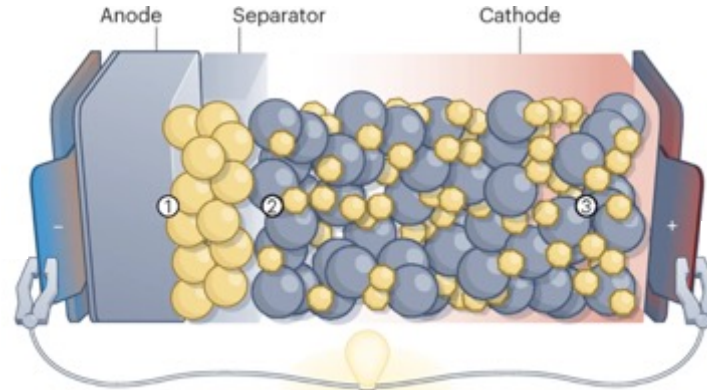
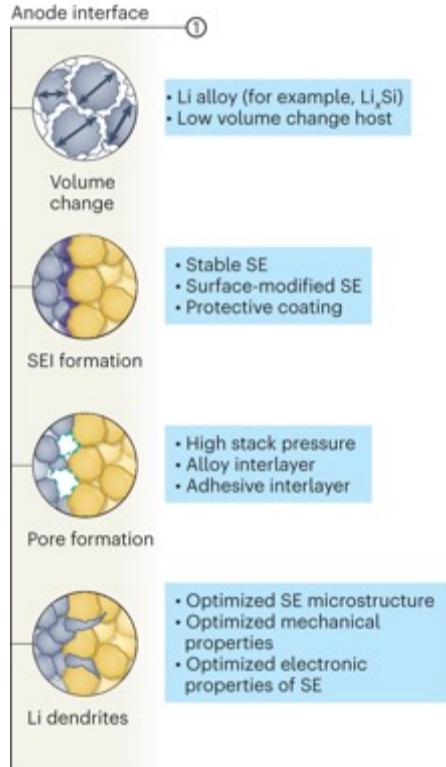

Variety interfacial challenges: interfaces, chemomechanics, and transport limitations...

...all as a function of all these different active materials and solid electrolytes

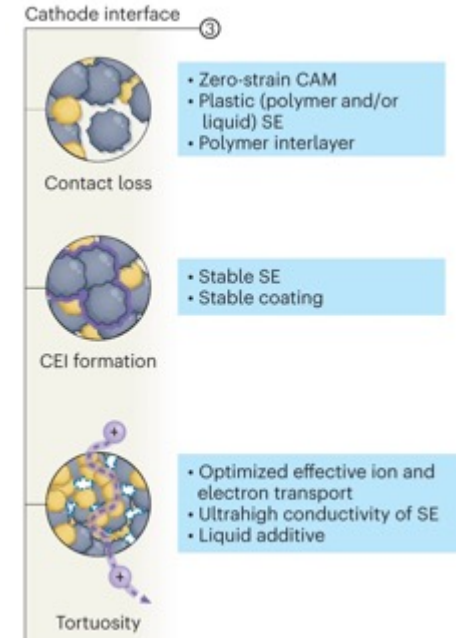

Optimizing transport in electrolytes and composites

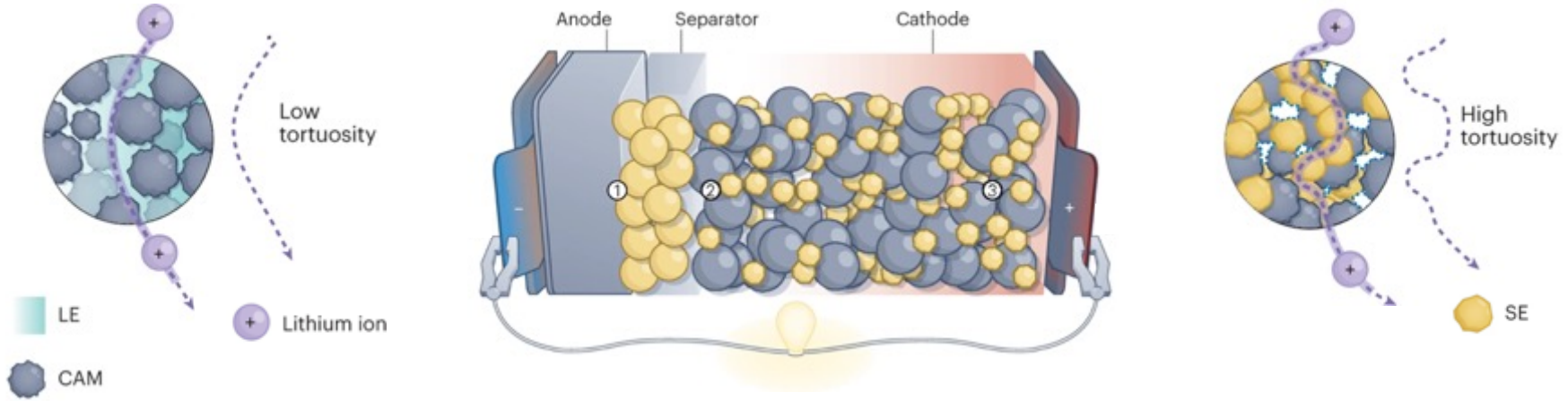

An electrochemical reaction needs both, ions and electrons in ample supply!

In other words, besides optimizing a solid state compounds property, we also need to optimize it in the application directly.

Problem: Depends on material, particle size, porosity, etc..

Solid-state batteries have local transport problems

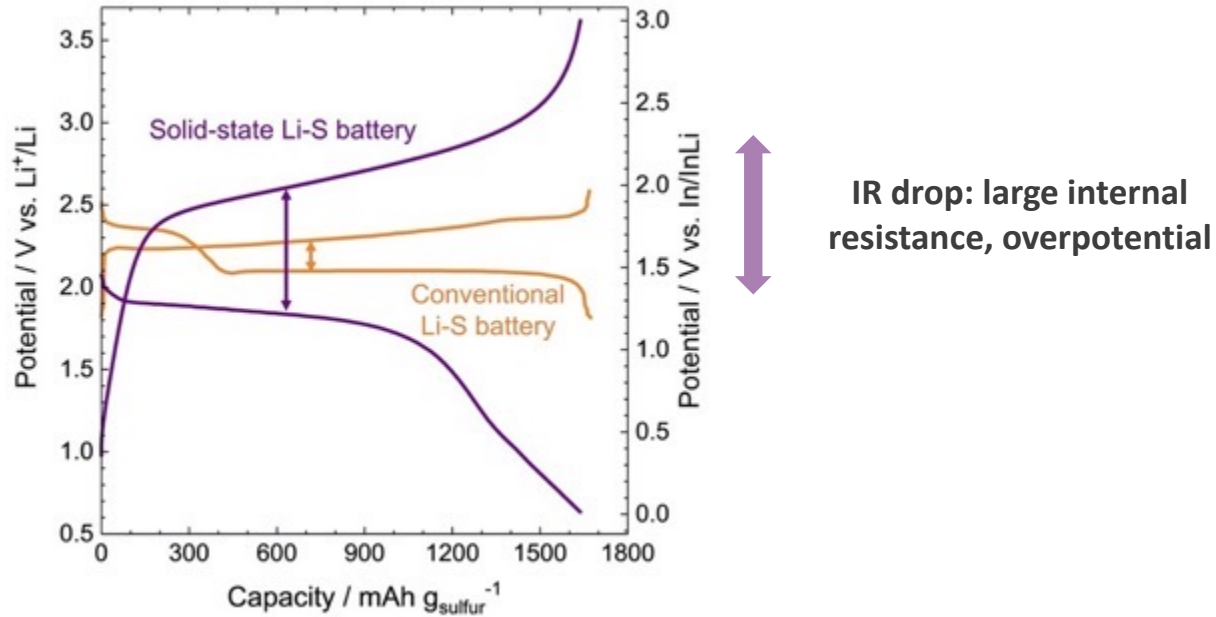

Often **larger overpotentials in solid-state batteries**, especially at high loadings and high current densities

Effective ionic transport decreases strongly in composites

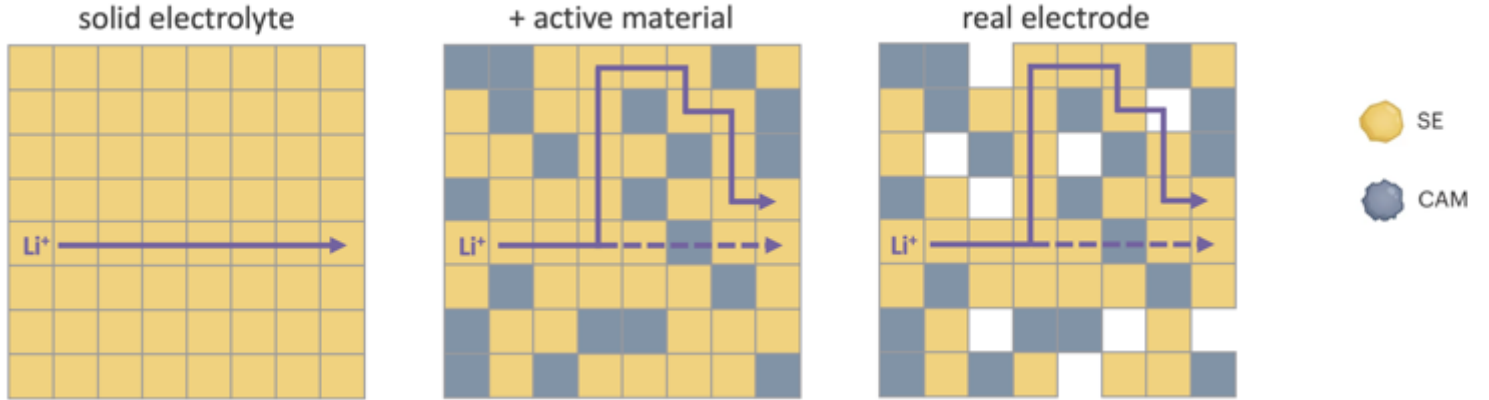

We now have an effective transport in two (**three**) phases, no longer just one!

Volume fraction of SE

Effective ionic conductivity

$$\sigma_{\text{eff}} = \frac{\varepsilon}{\kappa} \cdot \sigma$$

Tortuosity factor

Ionic bulk conductivity

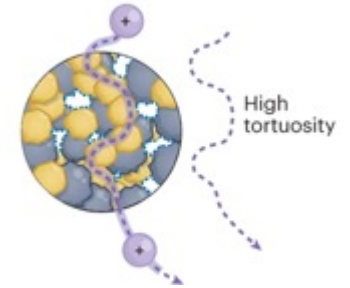

Effective ionic transport decreases strongly in composites

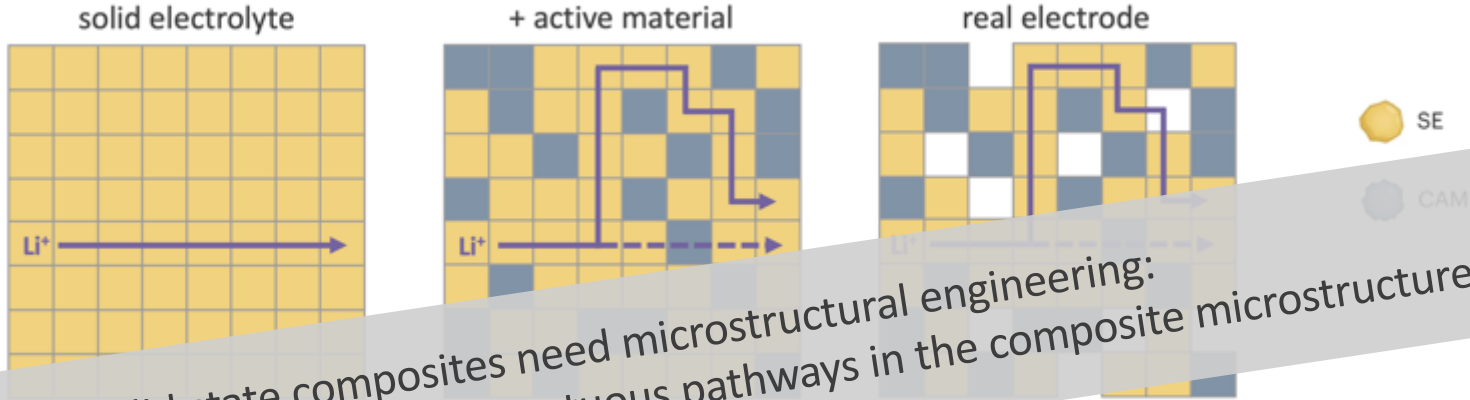

Solid state composites need microstructural engineering:
 (1) faster ionic conductors and (2) less tortuous pathways in the composite microstructure.

We now have an effective transport in two (**three**) phases, no longer just one!

Effective ionic conductivity

Volume fraction of SE

$$\sigma_{\text{eff}} = \frac{\epsilon}{\kappa} \cdot \sigma$$

Ionic bulk conductivity

Tortuosity factor

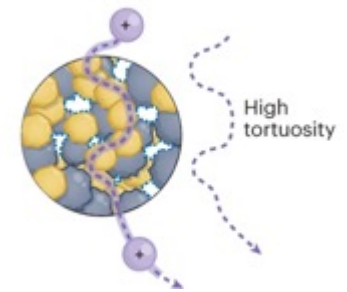

A short story on transport limitations in electrodes

Transport limitations in SSB

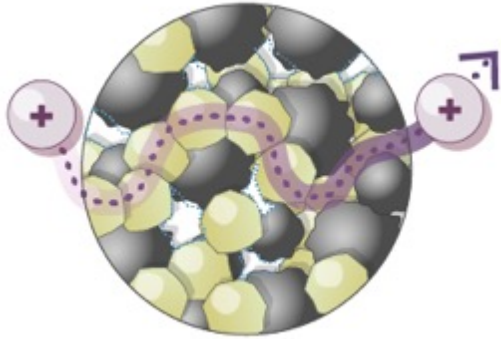

Streamline solid state composites

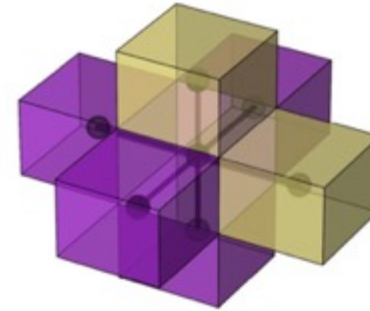

What else are these limitations affecting?

Transport limitations in SSB

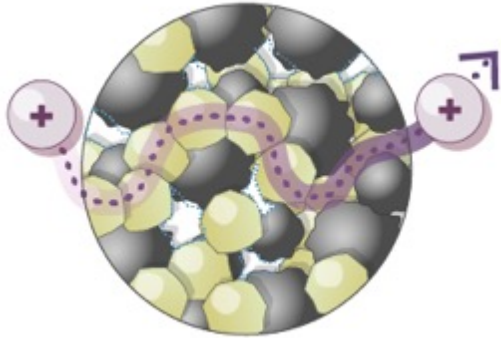

Streamline solid state composites

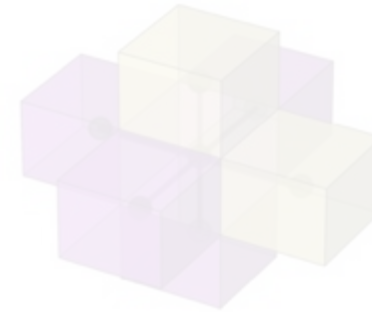

**Influence of tortuosity and transport in cathode composites not understood,
can we overcome them?**

Inhomogeneous reaction front observable in SSB

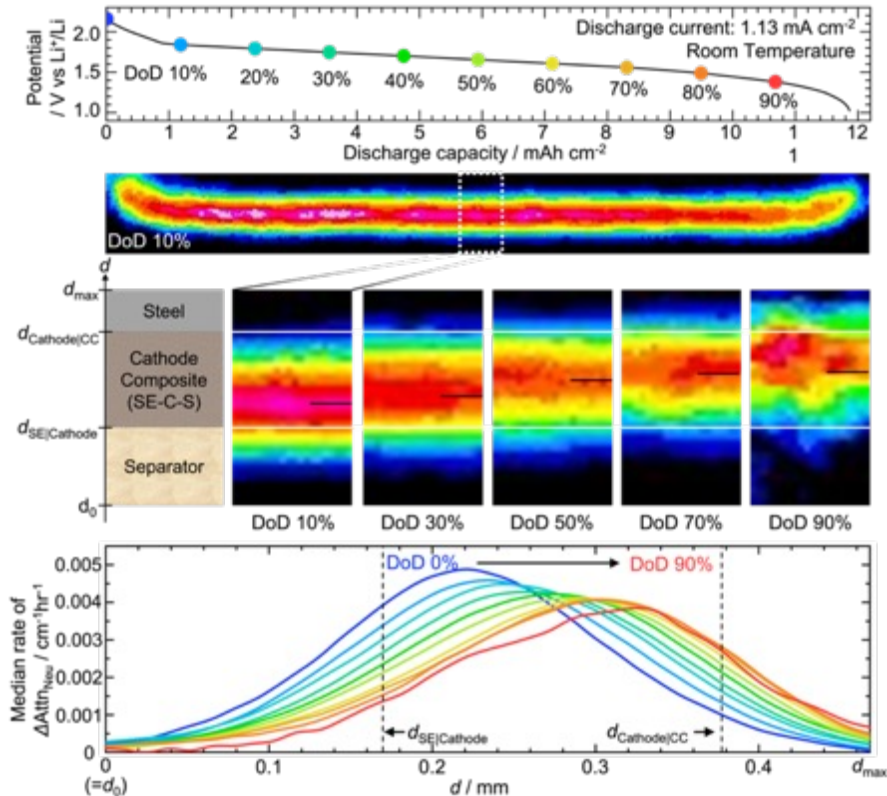

Discharge means S converts to Li₂S

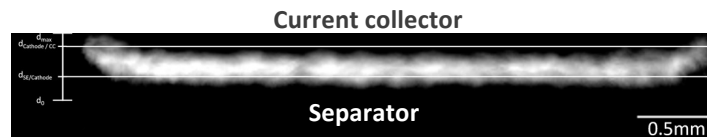

Reaction front starting from the separator visible due to transport imbalance!

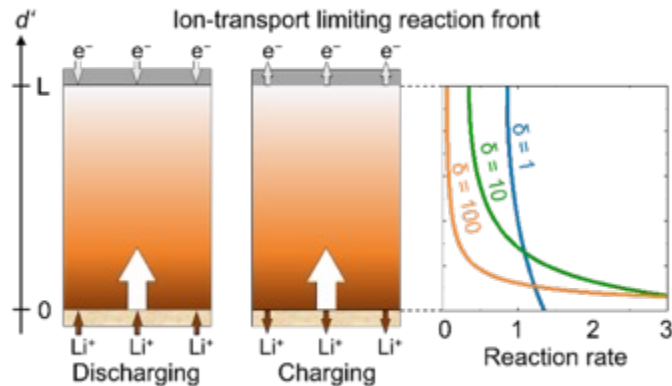

δ – parameter: balancing of transport parameters

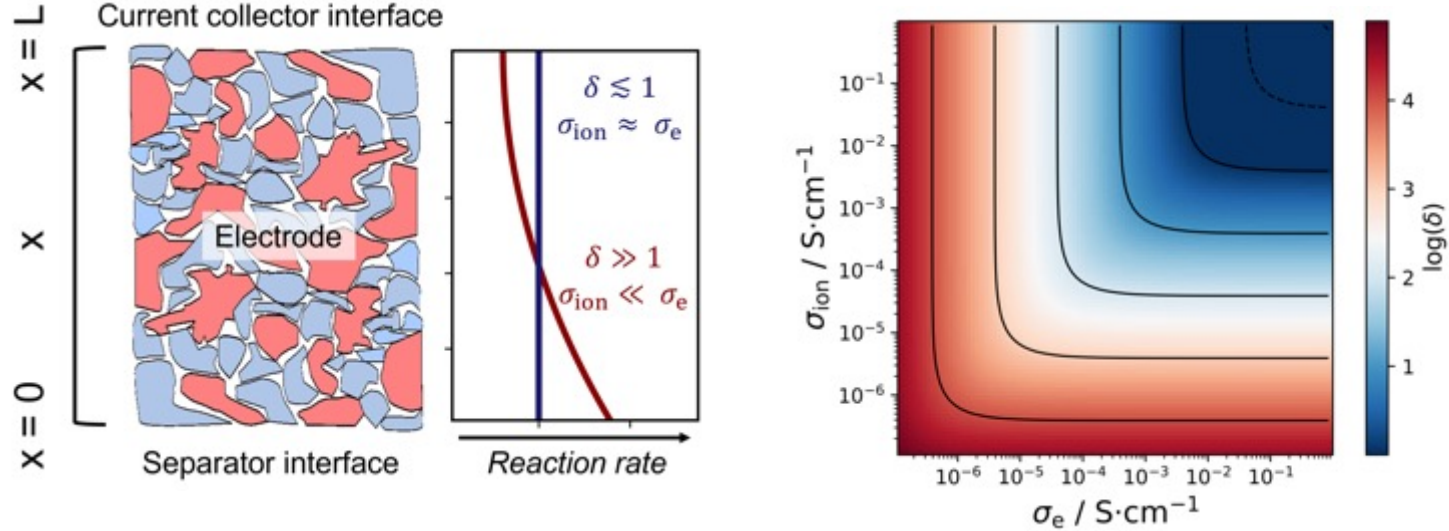

For homogenous transport, δ -parameter needs to be minimized:

$$\delta = L \cdot I \cdot \frac{nF}{RT} \cdot \left(\frac{\sigma_{\text{ion}} + \sigma_e}{\sigma_{\text{ion}} \cdot \sigma_e} \right)$$

- Increasing thickness L and
- increasing current density (C-rate)

What is this δ – parameter really?

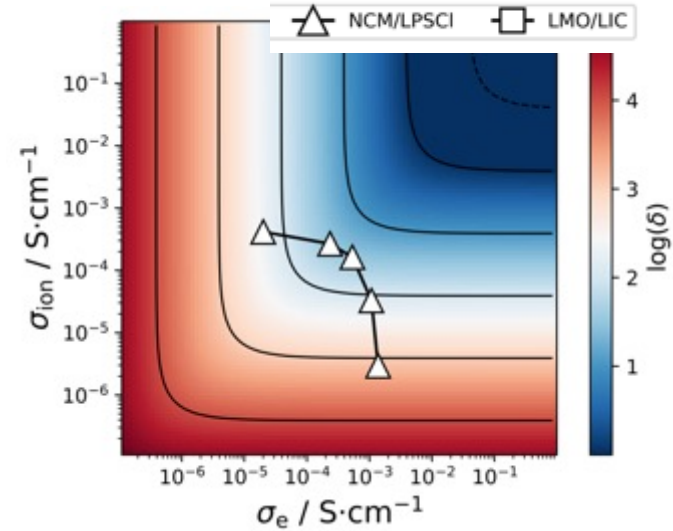
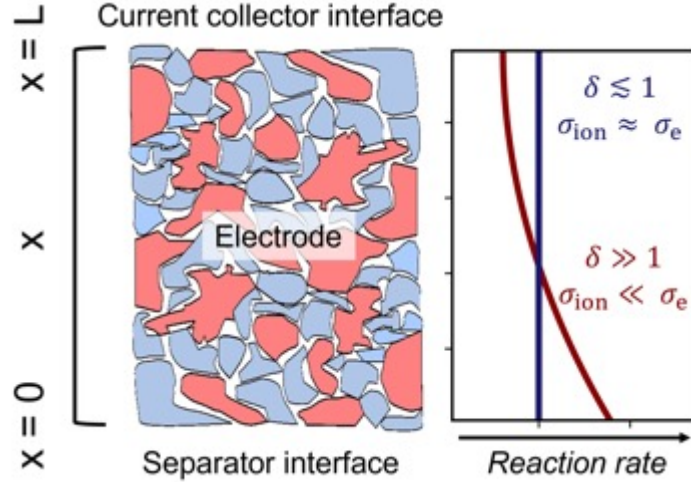

For homogenous transport, δ -parameter needs to be minimized:

$$\delta = L \cdot I \cdot \frac{nF}{RT} \cdot \left(\frac{\sigma_{\text{ion}} + \sigma_e}{\sigma_{\text{ion}} \cdot \sigma_e} \right)$$

- Increasing thickness L and
- increasing current density (C-rate)

What is this δ – parameter really?

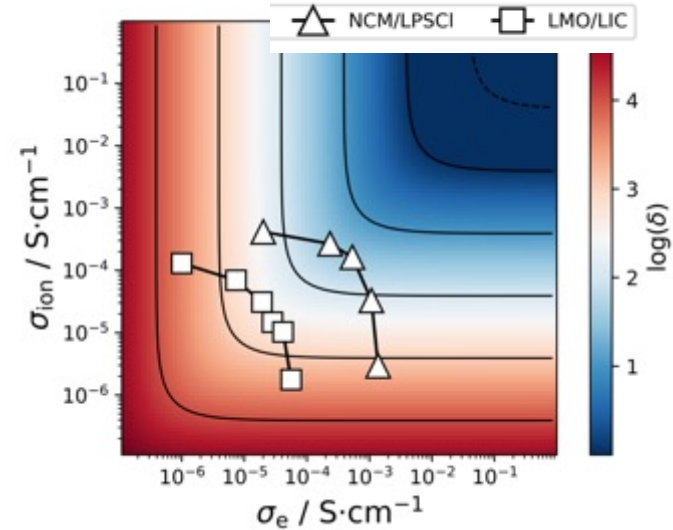
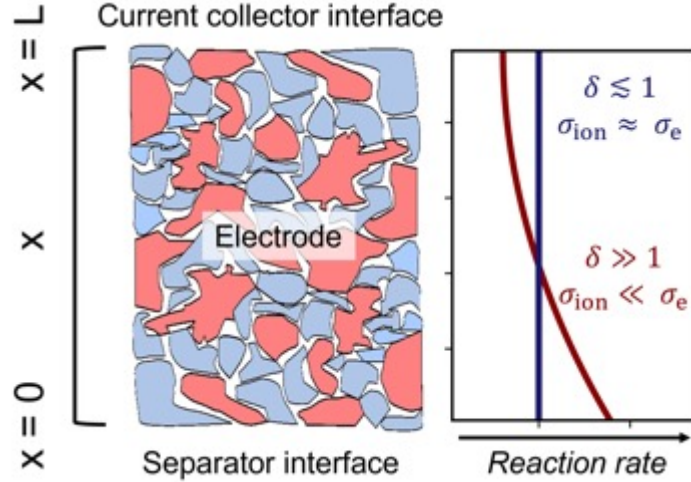

For homogenous transport, δ -parameter needs to be minimized:

$$\delta = L \cdot I \cdot \frac{nF}{RT} \cdot \left(\frac{\sigma_{\text{ion}} + \sigma_e}{\sigma_{\text{ion}} \cdot \sigma_e} \right)$$

- Increasing thickness L and
- increasing current density (C-rate)

For instance, taking $\text{LiMn}_2\text{O}_4 / \text{Li}_3\text{InCl}_6$ – balancing is important

How much energy we can store

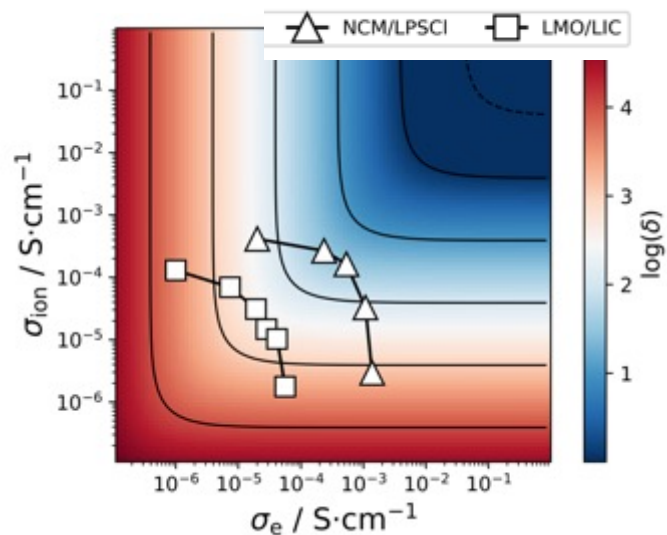
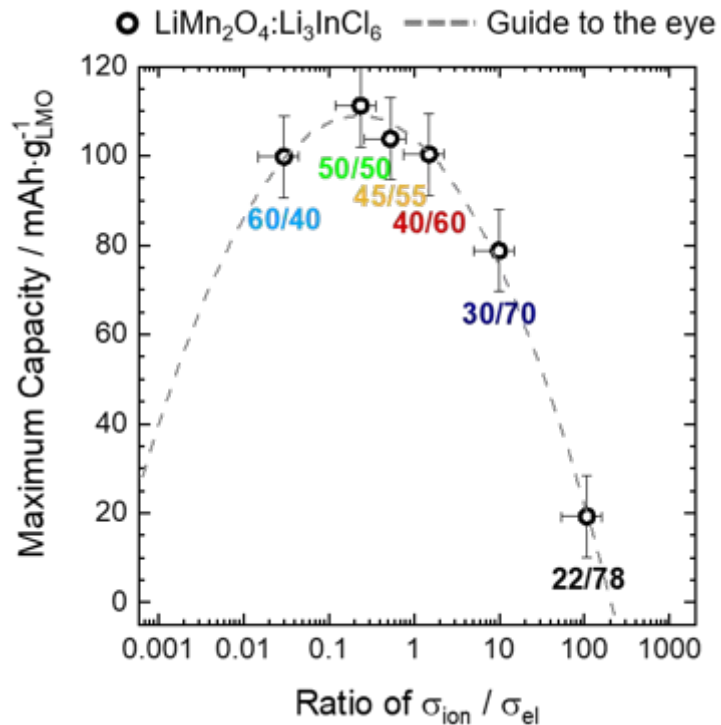

What is this δ – parameter really?

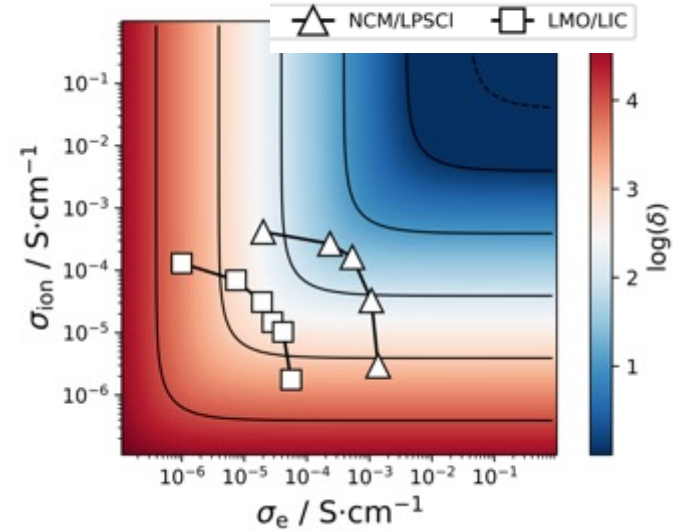
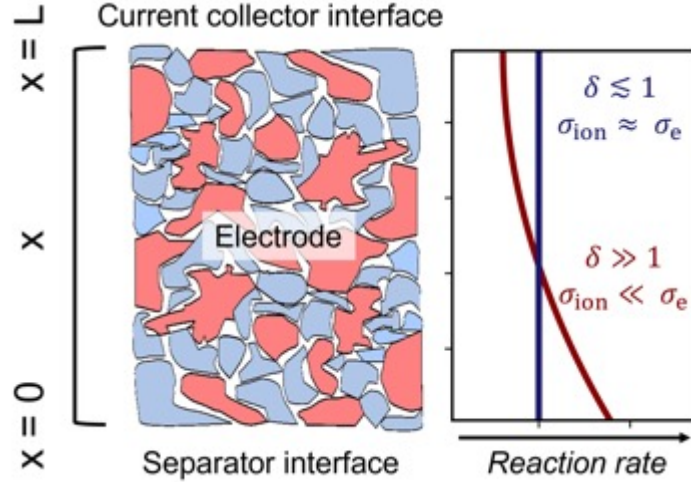

For homogenous transport, δ -parameter needs to be minimized:

$$\delta = L \cdot I \cdot \frac{nF}{RT} \cdot \left(\frac{\sigma_{\text{ion}} + \sigma_e}{\sigma_{\text{ion}} \cdot \sigma_e} \right)$$

**Quite some optimization,
especially when changing
compositions and
microstructures...**

Option 1: Playing with the particle sizes of the SE

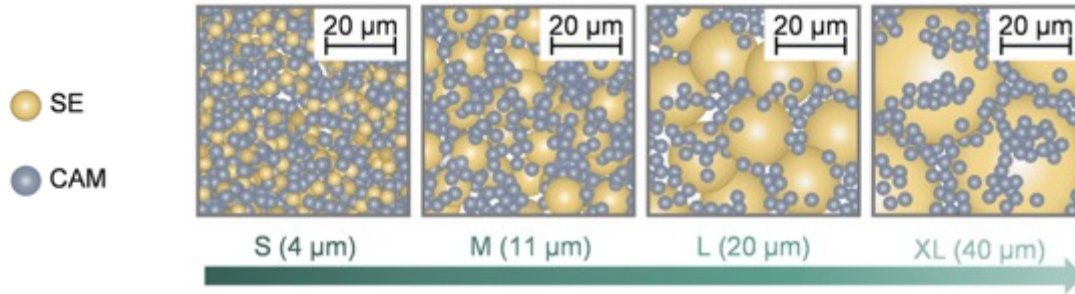

$\text{Li}_6\text{PS}_5\text{Cl}$ SE can have
different PSD...

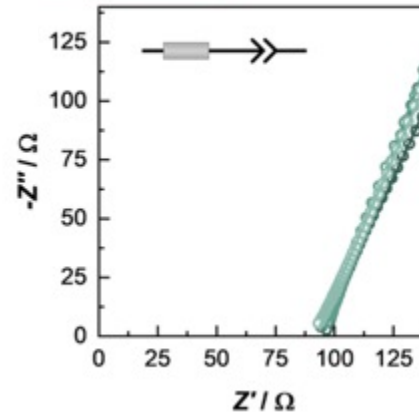
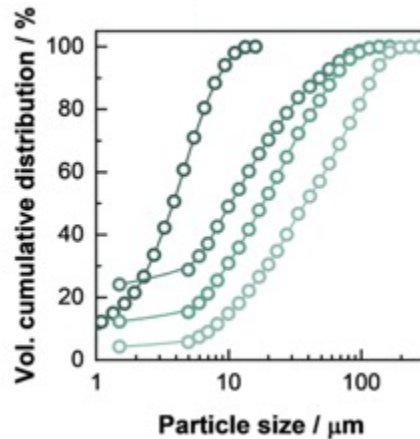

... and the
conductivity of the
SE does not change.

How does it affect cycling: part 1

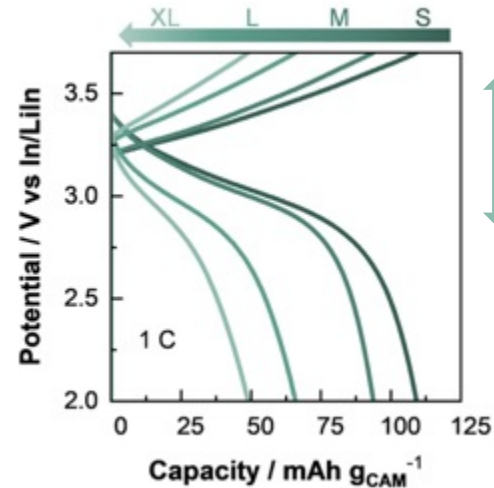
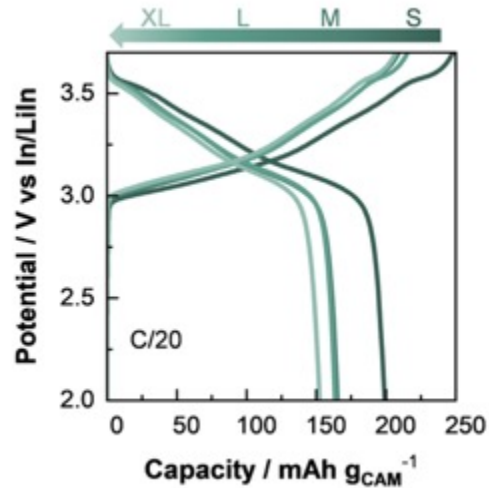

Higher overpotentials and lower capacity for larger SE particles.

Overpotential in the cells significantly affected at higher C-rates.

Clearly, resistance plays a role? But the conductivity of the SE did not change...

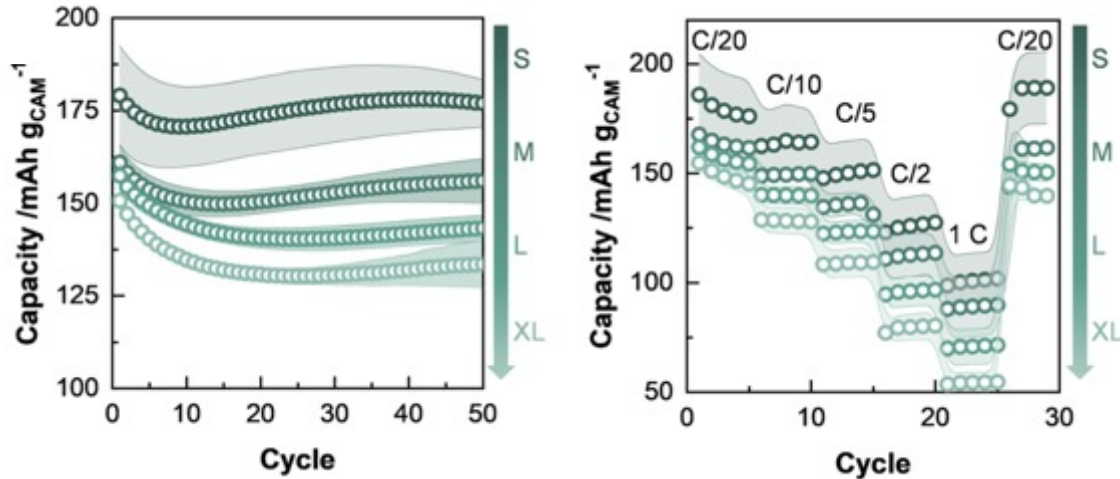

Lower capacity for larger SE particles. All triplicate cells.

C-rate tests also show smaller SE particles are better.

Question: How does the transport change in these composites?

Ionic transport changes, electronic does not

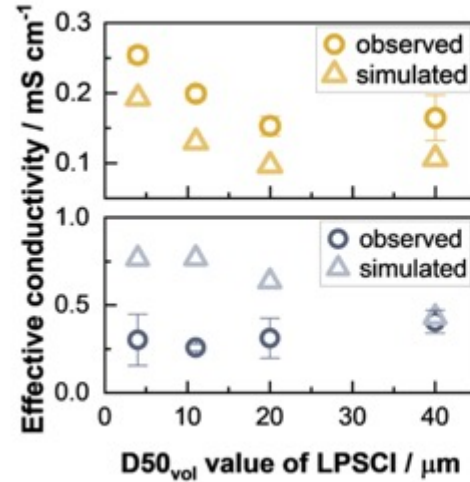
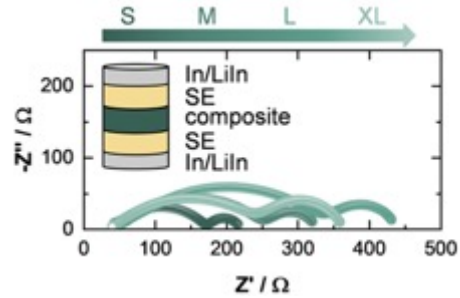

Capacity increases the closer both transport values are

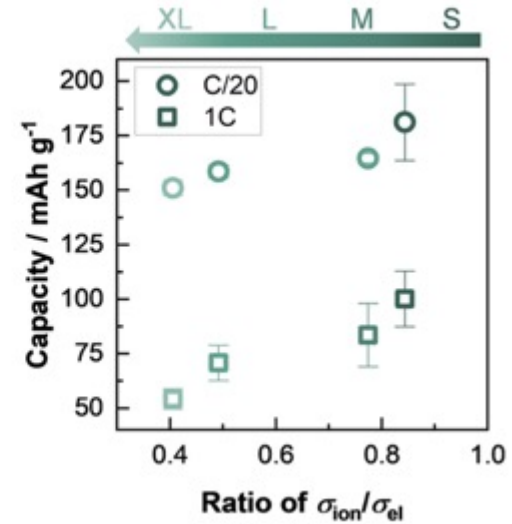
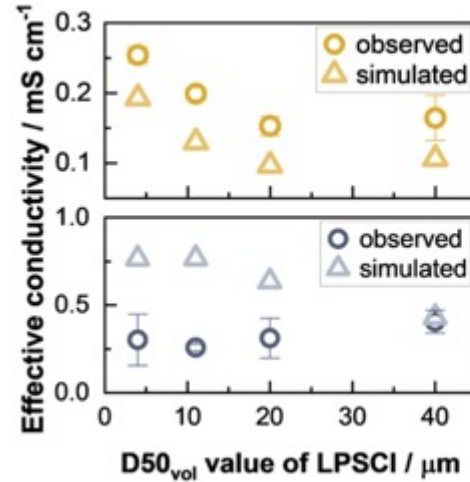
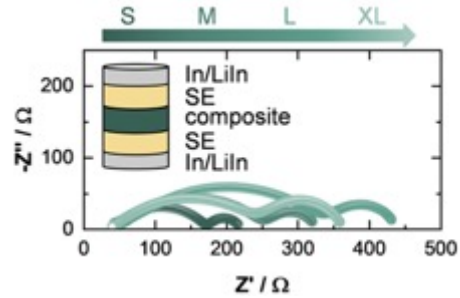

Small particles lead to higher and more uniform current

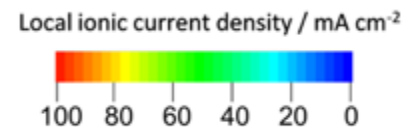
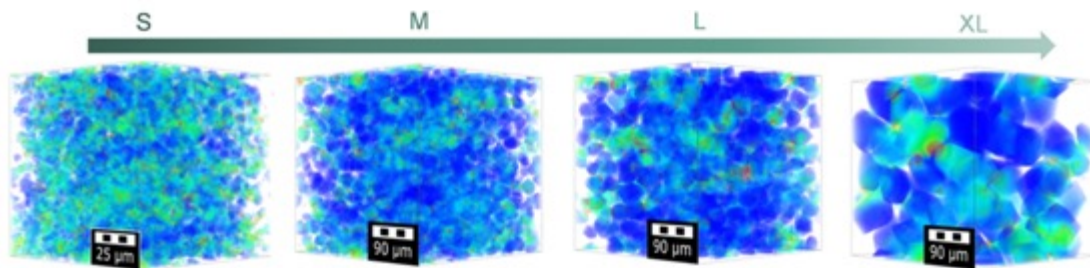
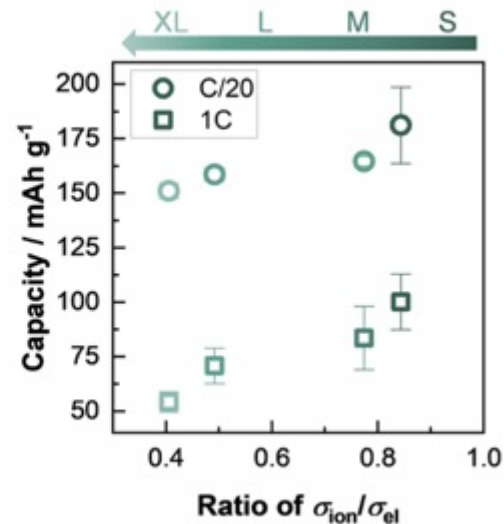
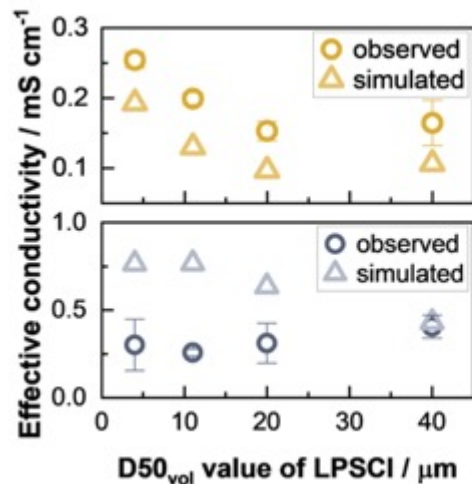
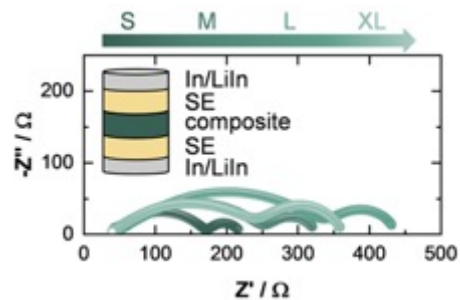

Option 2: Gradient design of electrodes

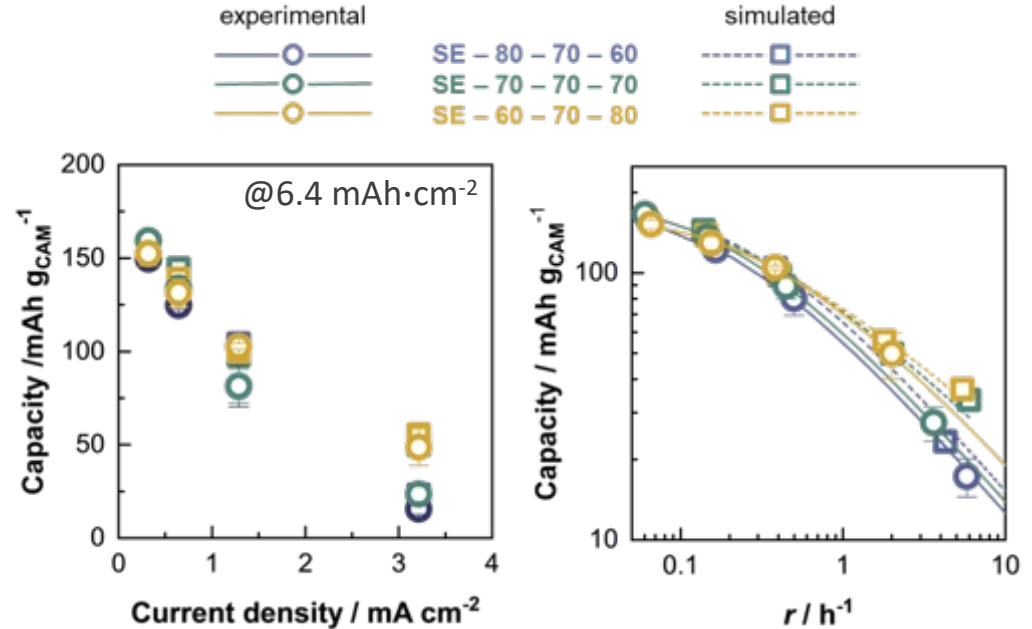
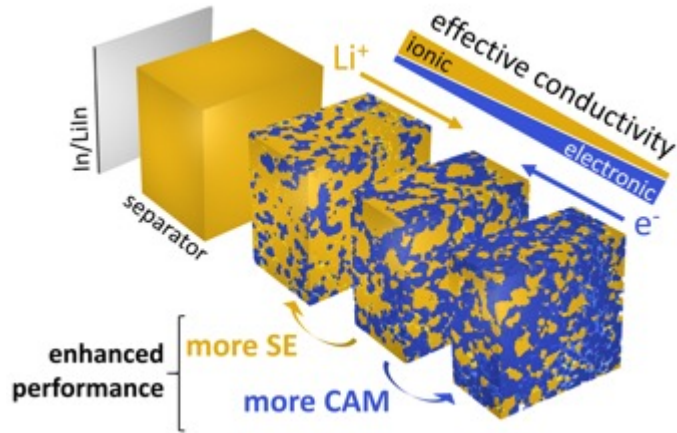

Measuring and understanding transport opens route for optimization!

Is it possible to streamline?

Transport limitations in SSB

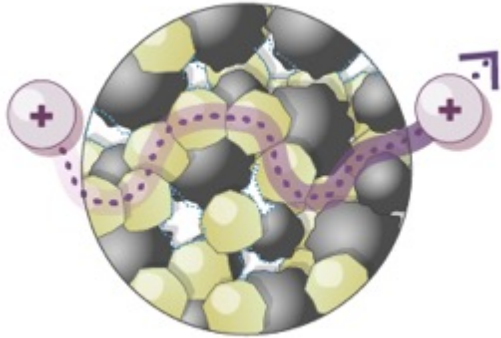

Streamline solid state composites

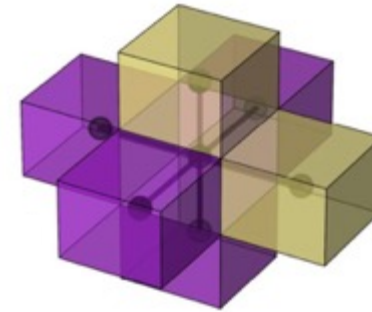

Measuring a property of a single system is one thing... but how can we streamline composite work?

Optimizing cells based on partial transport is tedious...

Huge parameter space

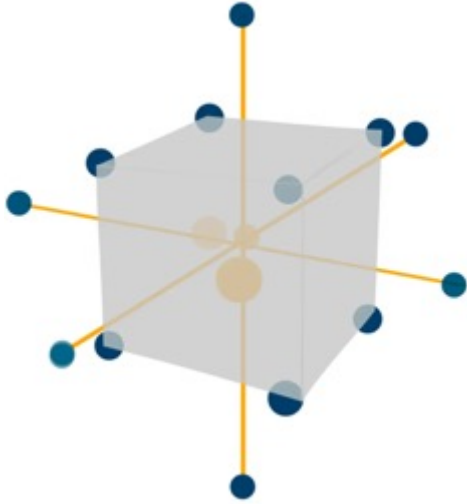

What if we could streamline this?

Optimizing cells based on partial transport is tedious...

Huge parameter space

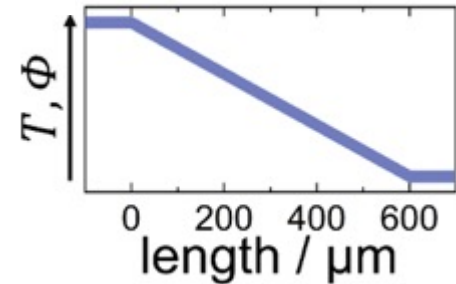
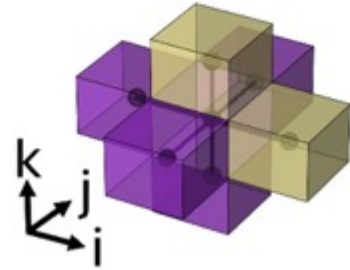
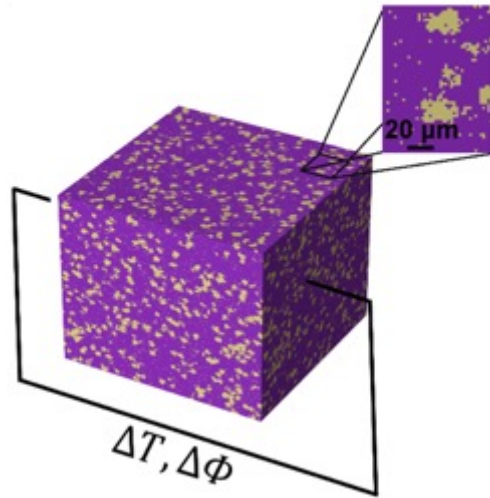
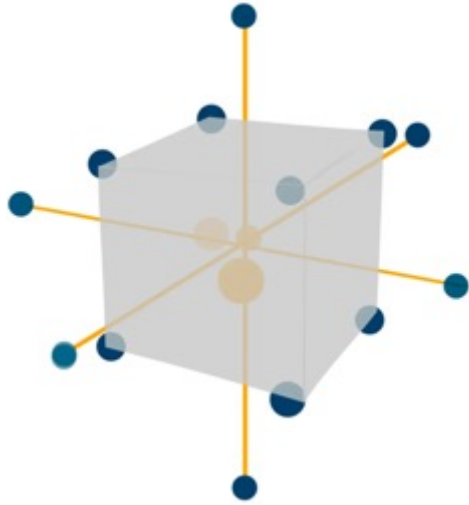

What if we could streamline this? Resistor – network models help.

Optimizing cells based on partial transport is tedious...

Huge parameter space

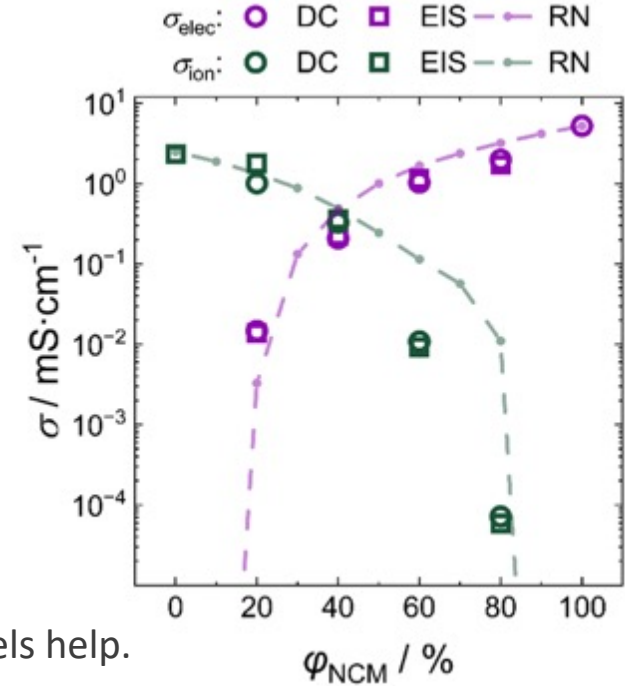
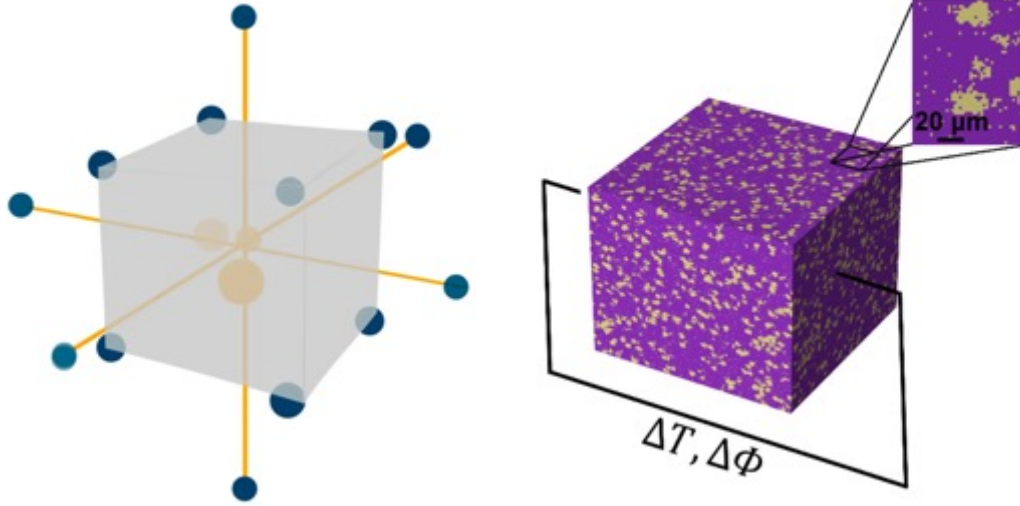

What if we could streamline this? Resistor – network models help.

Will not replace full continuum models for understanding, but faster starting point for experimentalists.

Resistor network model also captures thresholds

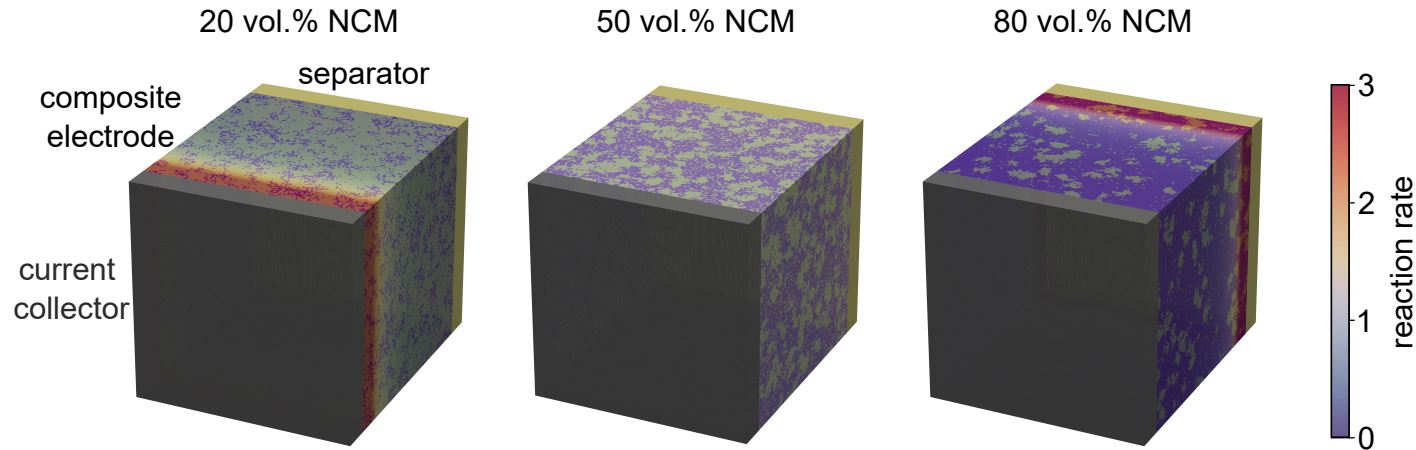

Resistor network model can be used to screen compositions and predict initial reaction rates using Newman model.

Minecraft science works!

Option 3: Faster solid electrolyte needed in thicker electrodes

In/LiIn | SE | NCM-83/SE

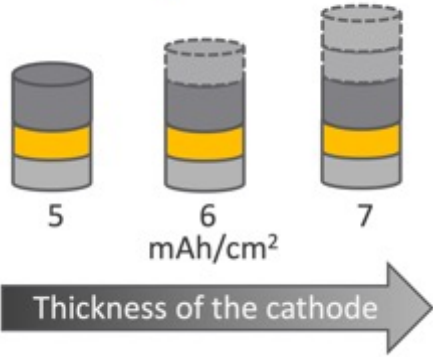

$$\delta = L \cdot I \cdot \frac{nF}{RT} \cdot \left(\frac{\sigma_{\text{ion}} + \sigma_e}{\sigma_{\text{ion}} \cdot \sigma_e} \right)$$

- | | |
|---------------------------------------|---|
| Li ₆ PS ₅ Cl | Li _{5.5} PS _{4.5} Cl _{1.5} |
| ● 5 mA _h ·cm ⁻² | ○ 5 mA _h ·cm ⁻² |
| ● 6 mA _h ·cm ⁻² | ○ 6 mA _h ·cm ⁻² |
| ● 7 mA _h ·cm ⁻² | ○ 7 mA _h ·cm ⁻² |

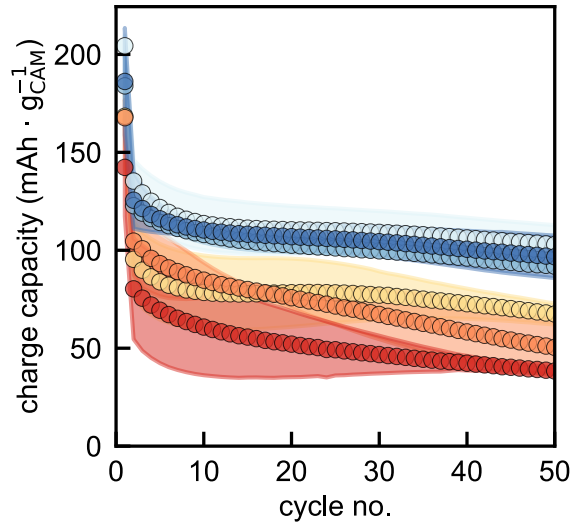

Less performance loss, if faster solid electrolyte is used in high loading SSB cells

Option 3: Faster solid electrolyte needed in thicker electrodes

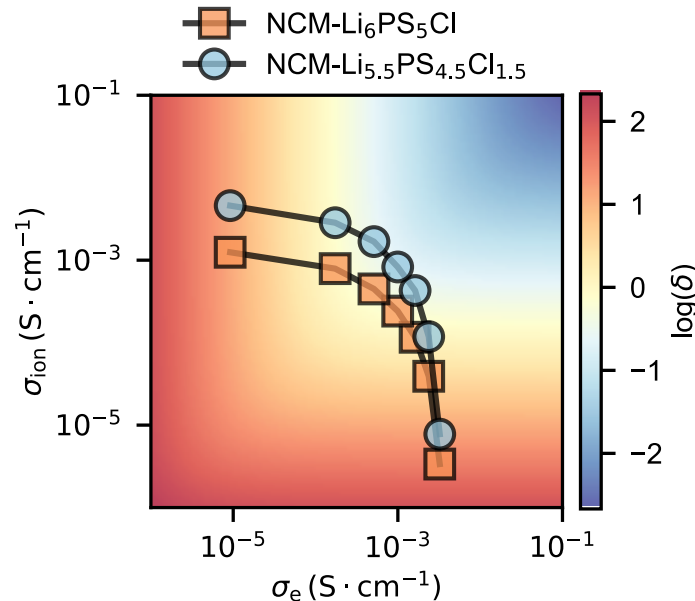
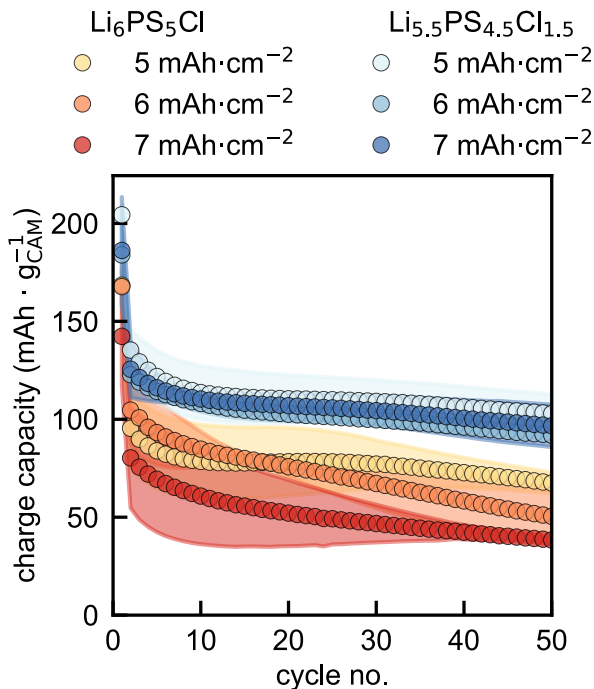
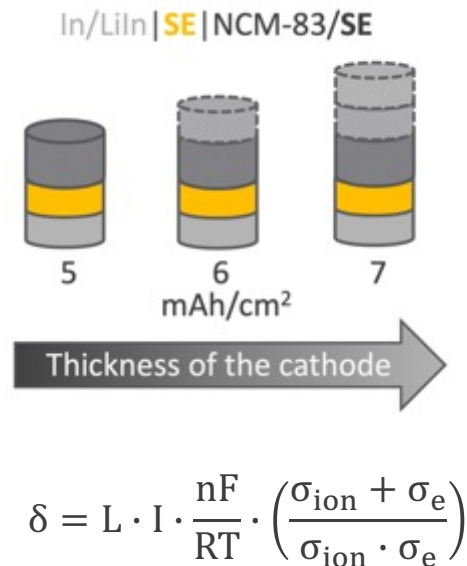

Less performance loss, if faster solid electrolyte is used in high loading SSB cells

Thank you for your attention

Solid state batteries are at the brink of commercialization.

Effective transport in composites and SSB needs to be measured and needs to be high.

Thick electrodes and more realistic loadings are a challenge for industry so far.



SPONSORED BY THE



Federal Ministry
of Education
and Research



Alexander von Humboldt
Stiftung/Foundation



Funded by
the European Union



European Research Council
Established by the European Commission



BACCARA



wzeier@uni-muenster.de
w.zeier@fz-juelich.de

